

Acoustic SL partition

High pressure laminated facings and rock wool core

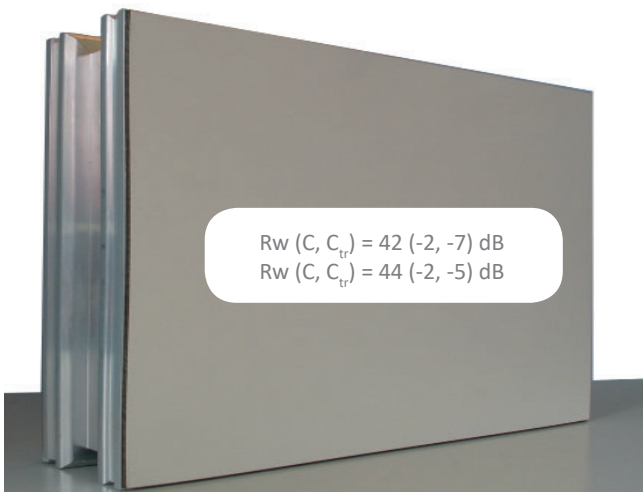

Partition consisted in modular panels of thickness 60 mm 2.36", an insulating rock wool core bonded between 2 high pressure laminated facings. Perfectly airtight and smooth it is very resistant against shocks and chemical aggressions. This modular structure is a specific variant with a very good sound reduction.

Design

Core

Insulated high density rock wool
Density : 200 kg/m³ 12.5 lb/ft³
Fire reaction (EN 13504-1): A1
Central hollow core
Glue : Polyurethane bicomponent

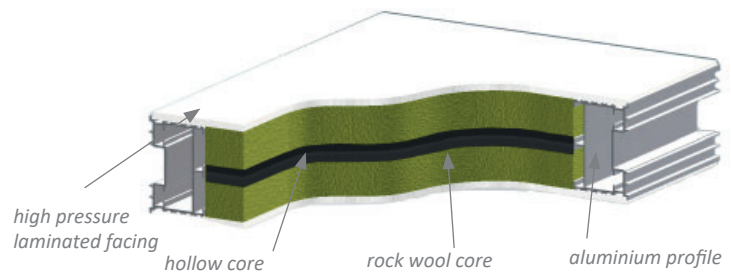

Facings

Variant A : high pressure laminated facings (HPL), compact flame-retardant, Thickness 4 mm 0.16", with anti bacterial treatment Sanitized®, food safe. Fire reaction M1 or B,s2-d0. Colour according to the colour chart Papago (data GSP-1209)

Variant B : high pressure laminated facings (HPL), compact flame-retardant, thickness 4 mm 0.16" + steel sheet 8/10th

Profiles

Aluminium alloy 6060 T5 (EN 573 standard)
Rustproof treatment (with bichromate or electro-zinc)

Technical characteristics

Panel

		Variant SL6A	Variant SL6B
Thickness		60 mm 2.36"	
Dimensions	Width	0,80 m 2.6'	
	Maxi. length	3,00 m 9.8'	
Weight		20 kg/m ² 4.1 lb/ft ²	27 kg/m ² 5.5 lb/ft ²
Weighted sound reduction index (according to NF EN ISO 717-1)		Rw (C, C _{tr}) = 42 (-2, -7) dB	Rw (C, C _{tr}) = 44 (-2, -5) dB

Acoustic SL partition

High pressure laminated facings and rock wool core

Installation

Assembly

SL panels integrate in their thickness, aluminium profiles enable the assembly of panel and the passage of cables. The assembly is made with an aluminium key which is fit into the groove of the longitudinal shores for the vertical panels.

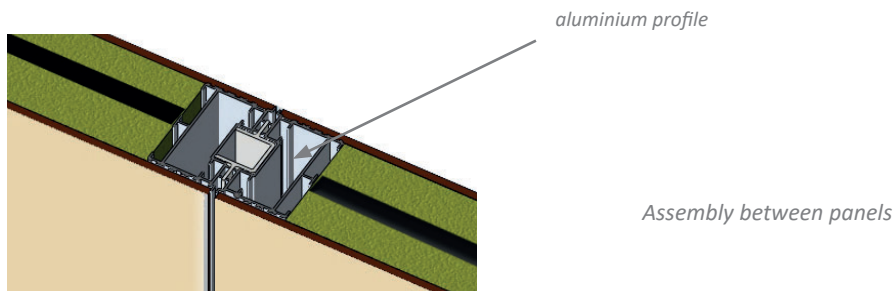

Tightness

- Mastic MS polymer

Reports and approvals

Fire reaction panel SL60:

Euroclasses = B-s1,d0

Consult the data n°0112 «Reports and approvals».

Acoustic performances

SL6A

$R_w (C, C_{tr}) = 42 (-2, -7) \text{ dB}$

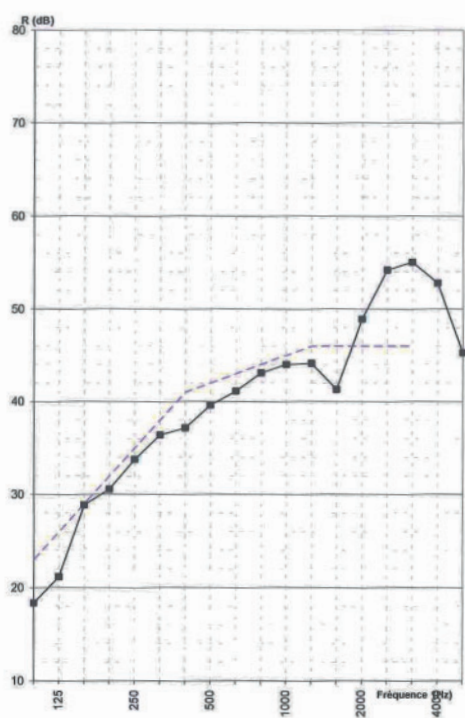

SL6B

$R_w (C, C_{tr}) = 44 (-2, -5) \text{ dB}$

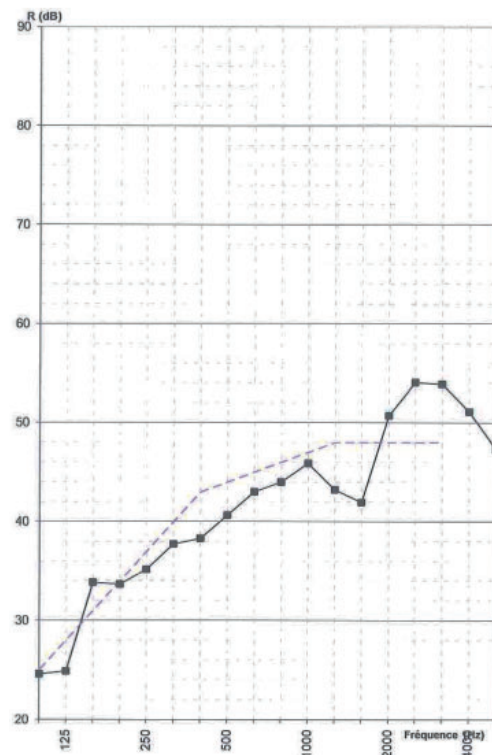

Airtight double flush glazing

GSP-0220-F/B



Glazings are monobloc elements of thickness 60 mm 2.36" made of two laminated glasses mounted flush on a black aluminium profile with tightness on the periphery.

They can be incorporated into walls (SI, SM, ST, SL) on site.

Application

These glazings can be used in premises where the relative humidity not exceeded 75% and with a temperature between +10°C 50°F and + 40 °C 104°F.

The use of 100 mm 3.94" wide mullions increases the glazed surface (SI, SM range).

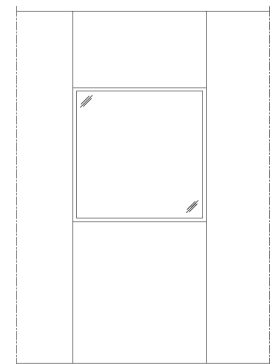

Glazing between 2 panels
(SI/SM/ST/SL)

Characteristics

Glazings are bi-glasses made of black (RAL 9005) aluminium profile on which is bonded 2 laminated glasses 44.2 (according to the standard NF EN14449) with 2 peripheral inserts (containing molecular riddle or dryer).

A silicon joint is extruded between glasses and aluminium profile in order to ensure the tightness, leaving the black (RAL 9005) peripheral aluminium profile visible. This profile enables the assembly between panels or glazings.

A decompression valve can be set on glazings send by plane or mounted at more than an altitude of 1100 m 3609'.

Weight 47 kg/m² 9.63 lb/f²
Coefficient U 2,66 W/m².k



EN14449-2

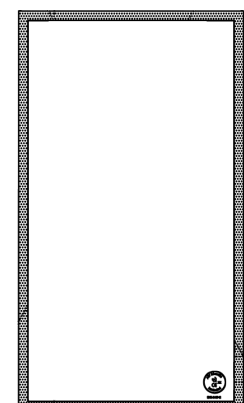
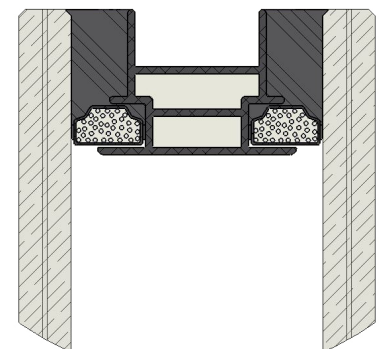

Standard dimensions

Height (B) x Width (A) (mm)

798 x 798 2.62' x 2.62'

998 x 798 3.27' x 2.62'

1198 x 798 3.94' x 2.62'

998 x 998 3.27' x 3.27'

1198 x 998 3.94' x 3.27'

1198 x 1198 3.94' x 3.94'

Other dimensions on request.

Airtight double flush glazing

Installation

Glazings are incorporated on site into SI, SM, ST or SL walls or between panels, spandrel and impost. A silicon joint assures the tightness between juxtaposed flush elements.

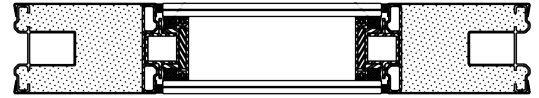

Mullion between glazings

Using mullions enables to increase the glazing surface.

The lacquered aluminium profiles are put between glazings in order to keep the partition rigidity. They can be used for the cable passage.

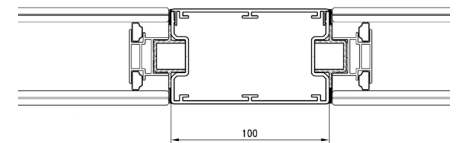

Variant with integrated blind only for glazings with thickness 60 mm 2.36''

For glazings of thickness 60 mm 2.36'', it is possible to integrate white Venetian blinds, manuals or automatics, and adjustable.

In manual control with rod or thin cord.

In automatic, control with remote control or button.



Glazed with inactinic film

Colored safelight films absorb light radiation between 300 and 570 nanometers in particular ultra violet radiation. They are used for protection against light and UV in production and control workshops, for example, for sensitive electronic equipment.

Up to 4 films can be stacked to obtain the performance required. The films are inserted between the glass during the manufacturing process of the glass. To be study case by case.

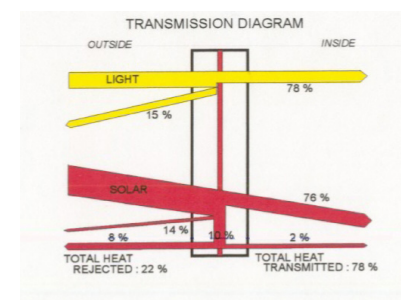

Mullion between glazings

GSP-0215-E/B



Positioned between two glazings, the mullion allows to stiffen the partition. It can be installed in a partition of thickness 60 mm 2.36" made of Ultra-Clean line panels.

Conception

Cover and support in lacquered aluminium, width 100 mm 3.94", thickness 60 mm 2.36".

Basis length of 4 m 13.12' with specific adaptation piece at bottom for assembly on adjustable belt.

It also allows the passage of cables or other fluid.

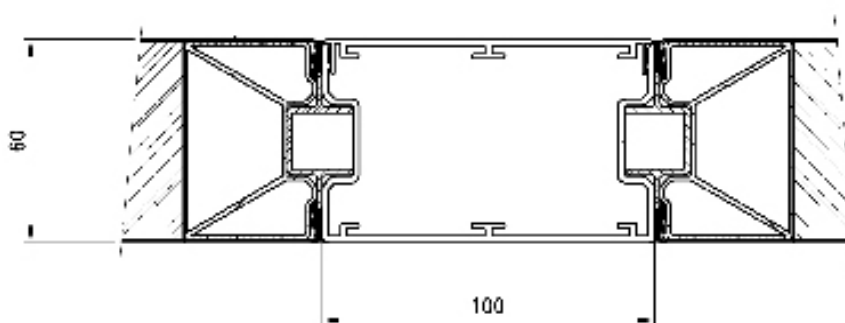



The electrical raceway enables the passage of cables and accessories gathering between two panels of thickness 60 mm 2.36" from the Ultra-Clean line.



Description

The support and the cover are in lacquered aluminium, of width 100 mm 3.93", of thickness 60 mm 2.36", of basis length of 4 m 13.12" with a flat T-bracket for the mounting on adjustable belt.

As the cover is fixed last, the cables can be set up after the partition mounting.

All is totally recessed in the partition thickness and is flush on the two sides without visible fixings.

Technical characteristics

The removable cover enables to integrate different electrical accessories on semi-flush or flush way.

- power socket, RJ45,...
- switch
- push button, lights,...
- signal lamps

The electrical race way could be divided strong current-weak current.

Openings, only on one part of the cover, are possible in factory or on site.

Installation is the same as mullion mounting.

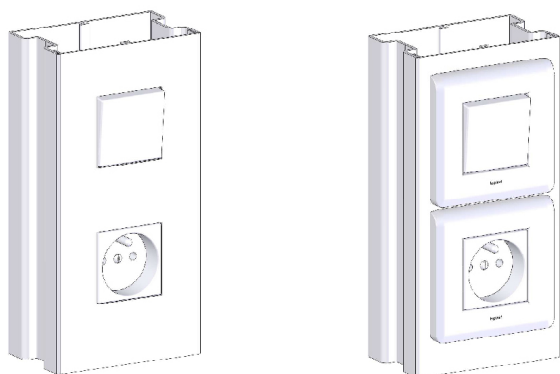

Electrical race way

Option - Equipment set on factory

Electrical accessories are usually not provided with the race way, however, it is possible to prepare in factory pre equipped raceways, where accessories and wiring are integrated and sealed.

NB : these raceways can be used for passage of different fluids (air, gas, ...)

example of installation

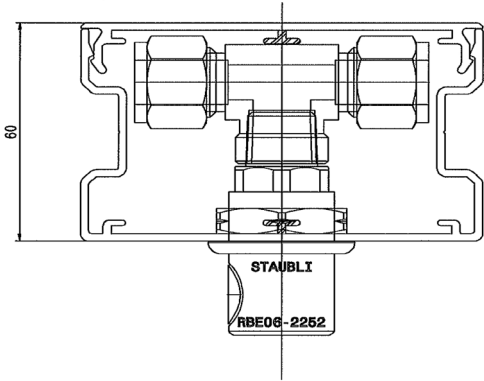

Acoustic double flush door steel leaf 60

Flush frame for panels 60 mm, leaf 60 mm

GSP-00806-E/A

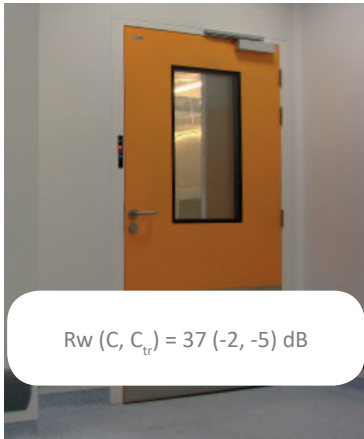

Service door with flush frame on the 2 sides of the partition.
The leaf, double flush, is consisted of mineral wool - polypropylene honey comb - mineral wool bonded between 2 metallic facings.

Technical characteristics

Leaf

- 1 or 2 leaves thickness 60 mm
- sandwich structure
- mineral wool core thickness 24 mm - polypropylene honey comb thickness 11,5 mm - mineral wool thickness 24 mm and aluminium structure profiles
- facing in smooth galvanized steel sheet 8/10, mechanical welded, and painted with epoxy-polyester powder, heat-cured, Iceberg white colour (close to RAL 9010), options : colours according to the colour chart (GSP-1208)

Door frame

- double flush monobloc for panels of thickness 60 mm
- lacquered aluminium frame, painted with epoxy-polyester powder, heat-cured

Options

- stainless steel frame
- lifting impost of dimensions 630, 730 or 830 mm for doors of dimensions 2040 x 1660 mm and 2040 x 2060 mm

Left or right opening

Tightness

Closed profile sealant, 10 mm 0.39" trimming at the bottom of the door.

	standards equipment	options	see data N°	
doors with 1 or 2 leaves	adjustable white lacquered aluminium hinges	adjustable stainless steel finishing aluminium hinges	GSP-0902-F/B	
		stainless steel hinges (no adjustable)		
	white PVC handle with cylinder-type safety lock (single keyway)		coloured PVC handle with european profile lock (single keyway)	GSP-0901-F/B
			stainless steel handle with european profile lock (single keyway)	
			white PVC pull handle (without lock) with push plate	
			stainless steel pull handle (without lock) with push plate	
	stamped stainless steel strike			
			panic push bar	GSP-0903-F/B
			floor gasket	GSP-0906-F/B
			sweeper gasket	
			door stop	GSP-0905-F/B
			wall mounting door closer	GSP-0904-F/B
			double flush vision panel 640 x 350 mm 2.10' x 1.15', 800 x 500 mm 2.62' x 1.64', 1000 x 500 mm 3.28' x 1.64'	GSP-0920-F/B
			grey PVC kick plate, height 850 mm 2.79' on 1 or 2 faces	GSP-0911-F/B
		stainless steel sheet kick plate, height 850 mm 2.79' on 1 or 2 faces	GSP-0912-F/B	
		recessed magnetic lock	GSP-0914-F/B à GSP-0919-F/B	
		airlock management		
doors with 2 leaves	lever bolt top and bottom on half fixed leaf		GSP-0907-F/B	
		closing selector	GSP-0904-F/B	

Acoustic double flush door steel leaf 60

Flush frame for panels 60 mm, leaf 60 mm

GSP-0806-E/A

Technical characteristics

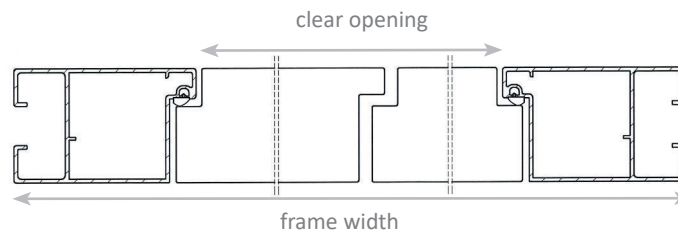

(mm)	designation H x W	clear opening H x W	door frame H x W	designation H x W	clear opening H x W	door frame H x W	designation H x W	clear opening H x W	door frame H x W
1 leaf	2040 x 630	2039 x 609	2135 x 801	2240 x 630	2239 x 609	2335 x 801			
	2040 x 830	2039 x 809	2135 x 1001	2240 x 830	2239 x 809	2335 x 1001			
	2040 x 930	2039 x 909	2135 x 1101	2240 x 930	2239 x 909	2335 x 1101	2440 x 930	2239 x 909	2535 x 1101
	2040 x 1030	2039 x 1009	2135 x 1201	2240 x 1030	2239 x 1009	2335 x 1201	2440 x 1030	2239 x 1009	2535 x 1201
	2040 x 1130	2039 x 1109	2135 x 1301						
2 leaves	2040 x 1260	2039 x 1244	2135 x 1436	2240 x 1260	2239 x 1244	2335 x 1436			
	2040 x 1460	2039 x 1444	2135 x 1636						
	2040 x 1660	2039 x 1644	2135 x 1836	2240 x 1660	2239 x 1644	2335 x 1836	2440 x 1660	2239 x 1644	2535 x 1836
	2040 x 1860	2039 x 1844	2135 x 2036						
	2040 x 2060	2039 x 2044	2135 x 2236	2240 x 2060	2239 x 2044	2335 x 2236	2440 x 2060	2239 x 2044	2535 x 2236

Reports and approvals

Refer to the data sheet n°0112 "Tests reports and approvals"

Acoustics performances

$$R_w (C, C_{tr}) = 37 (-2; -5) \text{dB}$$

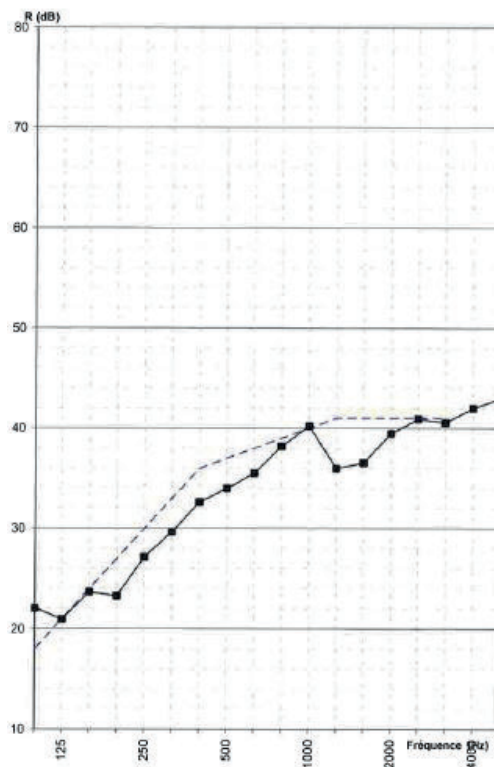

The connections of SI, SM, ST, SL, SA panels between themselves, with the floor or with the ceiling are adapted to the environment cleaning and decontamination restrictions the more strict.

Link with floor

By means of an adjustable metallic belt

The adjustable metallic belt enables the level to be adjusted while providing for a 5 mm 0.02" undercut here and there to enable the floor to be flush with the partition.

A coving profile fillet is available as an option to provide support for floor upsweeps (PVC or resin). On the outside face, a plinth can be installed.

Dimensions : 80 (-10 +30) x 50 mm 3.15" (-0.39"+1.18") x 1.97"

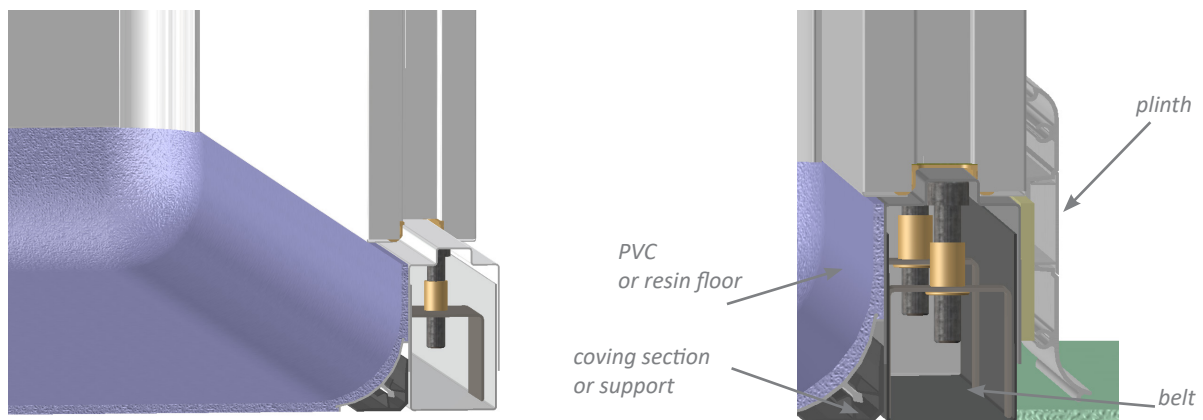

By U-shaped piece

Partition can be linked to the floor with a lacquered aluminium or PVC U-profile, 60 mm 2.36".

A plinth on one side or on each side of the partition ensures the finish.

Principle: Installation of U-profile on finished floor.

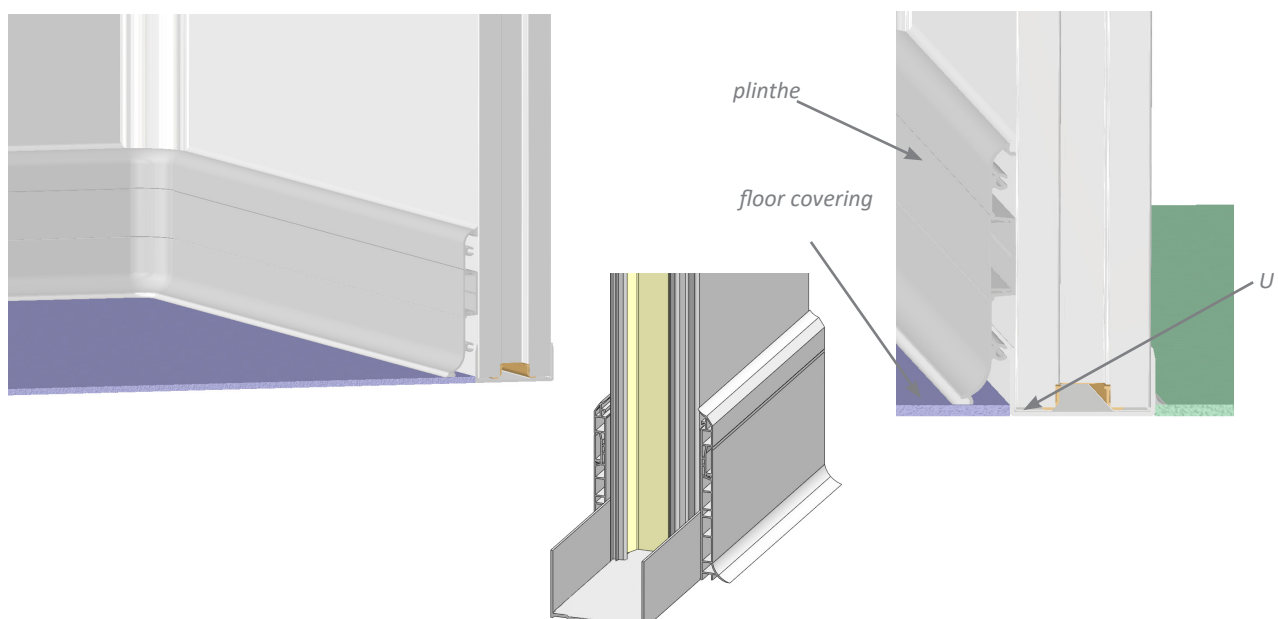

Junctions between vertical panels

Junction at coving profile

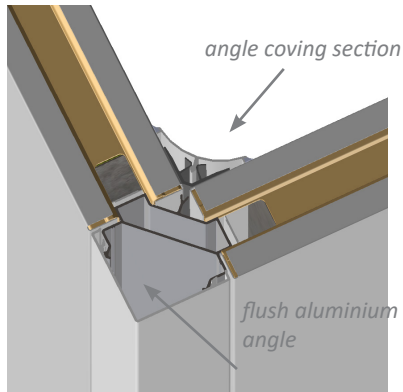

With a flush angle post

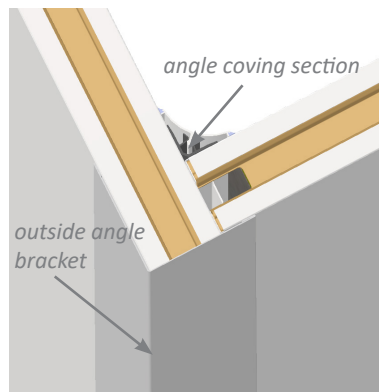

With a complement profile

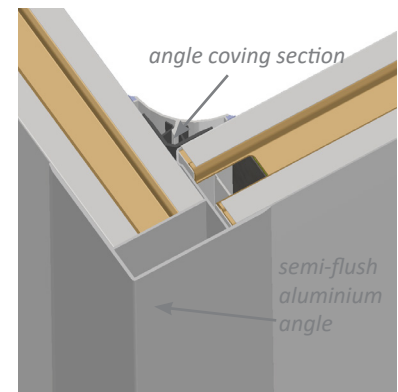

With semi-flush angle post

Junction in partition

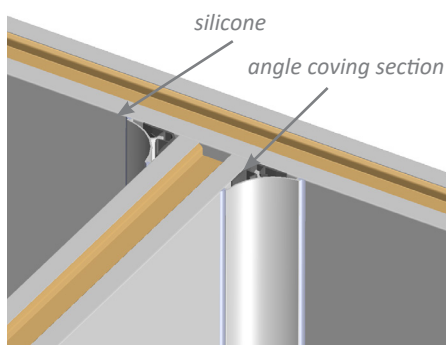

With PVC, aluminium, or stainless steel angle coving section

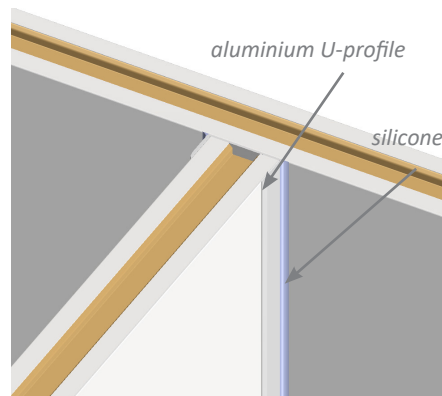

With aluminium U-profile

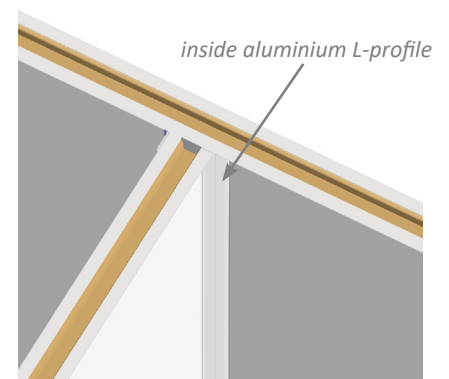

With aluminium L-profile

Junctions between ceilings and partitions

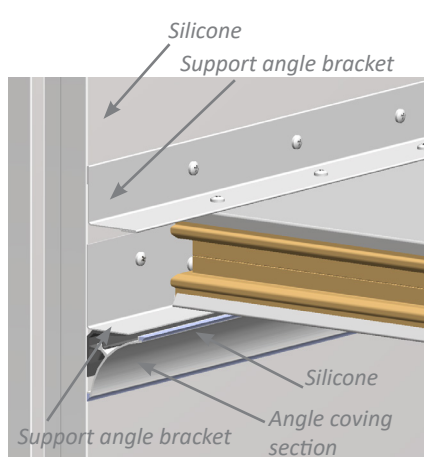

Junction ceiling to partition with load-bearing support on partition

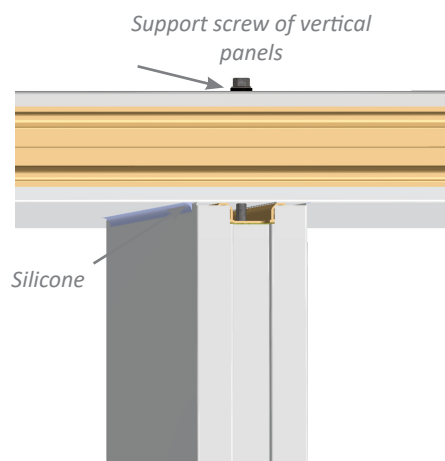

Partition under ceiling junction by direct screwing

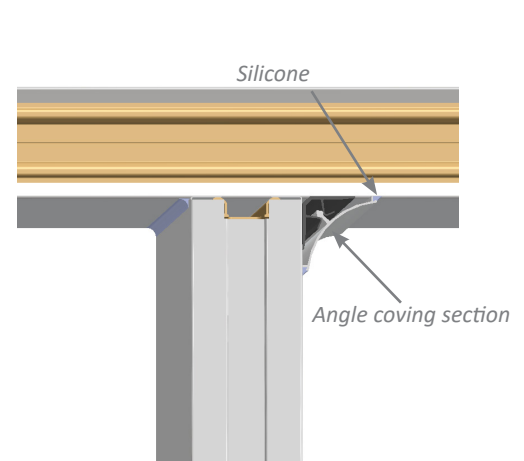

Partition under ceiling junction with fixing by angle coving section

Non walkable acoustic ceiling SA60

Metal facings and rock wool core

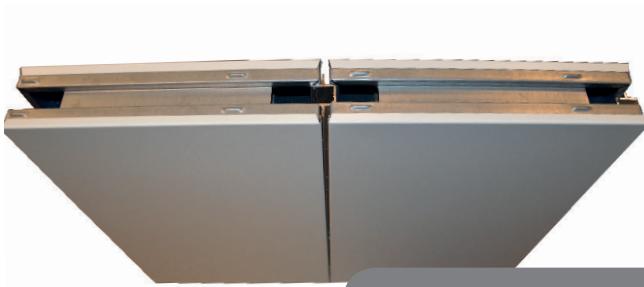

$R_w (C; C_{tr}) = 41 (-2, -6) \text{ dB}$

The acoustic SA ceiling is a non walkable ceiling made of removable modular panels with a strong sound reduction index.

The panels consist of an insulated rock wool core bonded between 2 metal facings and a central core in polypropylene honeycomb.

Design

Core

Insulates composite rock wool put in several special layers

Density : 200 kg/m^3 12.5 lb/ft^3

Fire reaction (EN 13504-1): A1

Glue : Polyurethane bicomponent

Central layer in polypropylene honeycomb.

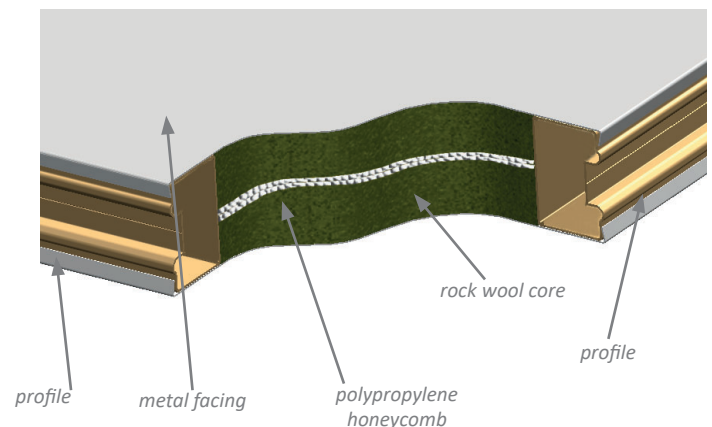

Facings

Support	Coatings according to NF EN 10169	Thickness (in mm)	Class according to XP P 34-301
Steel sheet S280 GD, hot-dip galvanised Z225 (225g/m ² of zinc on the 2 faces) or similar	coated with polyester 25 µm lacquer	0,8 0.03"	IIIa
	system PET 55 µm <i>on specific request</i>		Vc

Standard colour : iceberg white (close to RAL 9010)

NB: on request, the two facings can be of different materials on inside and outside faces (aspect, colour and/or thickness)

Profiles

Metallic profile for passage of cables.

Non walkable acoustic ceiling SA60

Metal facings and rock wool core

Technical characteristics

Panel

		SA60
Thickness		60 mm 2.36''
Dimensions	Maxi . width	0,80 m 2.6'
	Maxi. length	4 m 13.1'
Weight		30 kg/m ² 6.15 lb/ft ² (2 faces 0,75 mm 0.03'')
Weighted sound reduction index (according to NF EN ISO 717-1)		Rw (C;C _{tr}) = 41 (-2,-6) dB
Leakage rate		Qs ≤ 0,0027 m ³ /h.m ² 0.0088 ft ³ /h.ft ² under ΔP = 50 Pa 0.007 PSI

Installation

Assembly

The assembly is made with aluminium key witch is fit into the groove of the longitudinal shores of panels. The SA panel is used in **non accessible** ceiling with a span of 2,40 m 7.9' (To be protected by decking pressing on the aluminium profiles in phase of construction site).

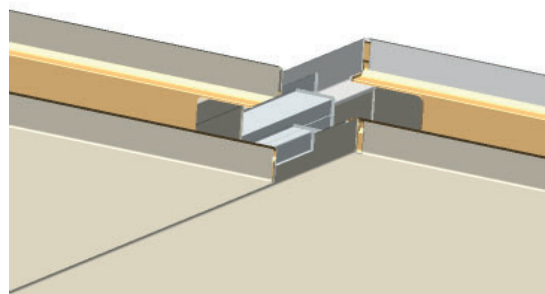

Assembly of 2 SA panels

Tightness

- Silicone caulk (quality-label SNJF ; complies FDA 21 CFR 175.105)
- Mastic MS polymer
- Flexible sealant in reticulate polyethylene, density 50 kg/m³ 3.12 lb/ft³, in the form of adhesive strip.

Reports and approvals

Acoustic performances

SA panel:

Weighted sound reduction index

Rw (C;Ctr)= 41 (-2;-6)dB

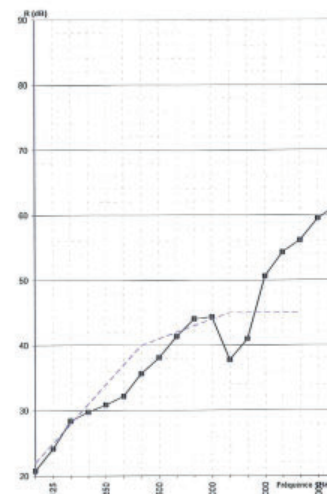

Consult the data n°0112 «Reports and approvals».

Ceiling fixings for panels SI-SM-ST

GSP-0219-E/B

Ceiling panels can be :

- self-supporting rests on the vertical partitions with, eventually, strengthening by «Omega» profiles or mesh wire frames or,
- suspended according to the span depending to the accessibility or not of the ceiling, to the size and the frequency of openings made for accessories integration.

Warning:

Ceilings cannot be used as walkways. They cannot be used as storage areas, temporary or definitively. They only support the occasional passage of one person for maintenance.

Ceiling secured by «Omega» fitting

Principle: Setting up of Omega fitting perpendicular or parallel to right of sealants.

The center distance between profile is according to the acceptable span of panels (limited at 2,40 m 7.87') or by the Omega capacity.

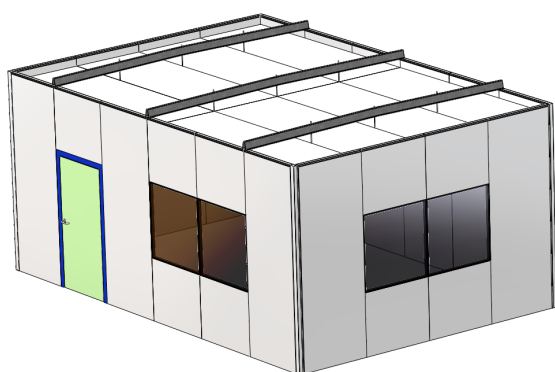

View of construction with suspension by Omega



Repartition piece

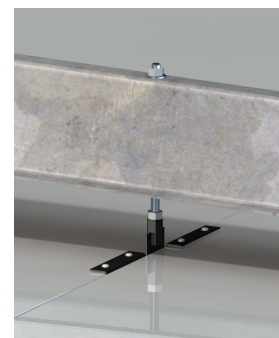

Panel fixing to the Omega

Omega height = 120 mm 4.7" or 170 mm 6.7"

	Omega height 120 mm 4.7" thickness 3 mm 0.11" I = 154 cm ⁴ I/v = 25 cm ³ maxi length = 6 m 19.7'	Omega height 170 mm 6.7" thickness 3 mm 0.11" I = 392 cm ⁴ I/v = 44 cm ³ maxi length = 7 m 23'
Omega span	Maximum centre distance between Omegas	Maximum centre distance between Omegas
until 4 m 13.1'	2,40 m 7.9'	2,40 m 7.9'
4,40 m 14.4'	2,00 m 6.6'	2,40 m 7.9'
4,80 m 15.7'	1,50 m 4.9'	2,40 m 7.9'
5,20 m 17'	1,20 m 3.9'	2,40 m 7.9'
5,60 m 18.4'	1,20 m 3.9'	2,20 m 7.2'
6,00 m 19.7'	1 m 3.3'	1,80 m 5.9'
6,50 m 21.3'	-	1,40 m 4.6'
7 m 23'	-	1,20 m 3.9'

Base of calculation:

Without clear elements, take into account

Uniformed load : 80 kg/m²

Safe deflection : 1/200th of span

Ceiling with mesh wire frame

Principle: Setting up of supporting mesh wire frames, braced together (at least 2) to make the ceiling self-supporting. The center distance between the frame elements is function of the acceptable span of panels (limited at 2,40 m 7.87') or the frame elements capacity.

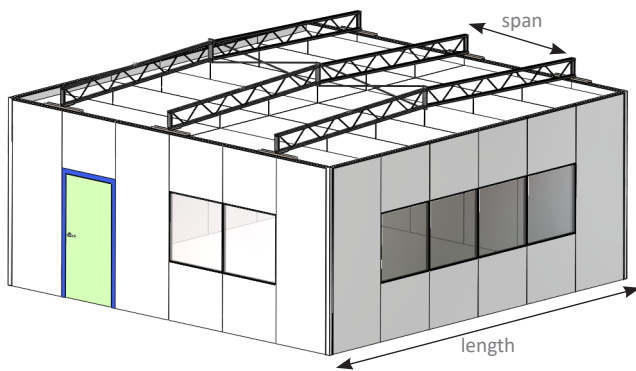

View of a construction with secured to supporting frame



Repartition piece



Fixing panel to frame

Framework height = 320 mm 12.6"

Frame length	Maximum span between frameworks	Frame length	Maximum span between frameworks
6,40 m 21'	2,40 m 7.87'	10,80 m 35.4'	2,20 m 7.21'
6,80 m 22.3'	2,40 m 7.87'	11,20 m 36.7'	2,00 m 6.56'
7,20 m 23.6'	2,40 m 7.87'	11,60 m 38.1'	1,80 m 5.9'
7,60 m 24.9'	2,40 m 7.87'	12,00 m 39.4'	1,70 m 5.58'
8,00 m 26.2'	2,40 m 7.87'	12,40 m 40.7'	1,50 m 4.92'
8,40 m 27.6'	2,40 m 7.87'	12,80 m 42'	1,40 m 4.59'
8,80 m 28.9'	2,40 m 7.87'	13,20 m 43.3'	1,25 m 4.10'
9,20 m 30.2'	2,40 m 7.87'	13,60 m 44.6'	1,15 m 3.77'
9,60 m 31.5'	2,40 m 7.87'	14,00 m 45.9'	1 m 3.28'
10,00 m 32.8'	2,40 m 7.87'		
10,40 m 34.1'	2,40 m 7.87'		

Base of calculation: Without clear elements, take into account

Uniformed load : 80 kg/m²

Safe deflection : 1/200th of span

Ceiling fixings from building

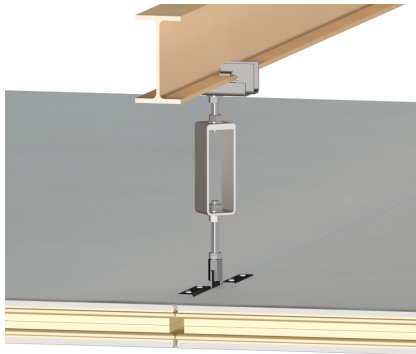

Suspension to metallic framework parallel to ceiling by single tensioner (threaded rod, nut, socket, pliers, tensioner, ceiling support)

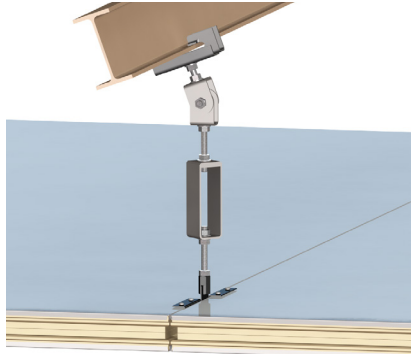

Suspension to frame with swivelling fitting nonparallel to ceiling by tensioner and adjusting hanger



Suspension under concrete slab by fastened with bracket fixed with 2 plugs

Other type of suspension : double fixing by rudder on purlin.

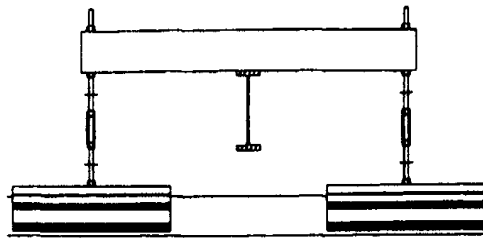

You must define your project indoor and the outdoor type of atmosphere in order to select the most appropriate types of panel facings.

Indoor atmosphere

With no clean room specific data, we have to reply on food and food processing industries classification for metallic panel facing types.

Aggressivity	Cleaning	Hygrometry	Temperature	Examples	Minimum category of appropriate coatings (NF P34.301)	Recommended coatings
Ai 1 Non-aggressive environment	Regular maintenance	Low	-40°C to +25°C -40° to +77°F	Storage of wrapped dry products	I	Polyester 25 µm PVDF 35 µm PVC 120 µm PET 55 µm Stainless steel 304 Stainless steel 304 + PVC + PET
Ai 2 Non-aggressive environment	Regular maintenance	Average	0°C to +25°C +32° to +77°F	Storage in controlled atmosphere	II	
Ai3 Non-aggressive environment	No Intensive cleaning	High	0°C to +25°C +32° to +77°F	Storage, processing moist ambient	IIIa	
Ai4 Slightly aggressive environment	No Intensive cleaning	High	0°C to +30°C +32° to +86°F	Preparation of pre-cooked foods	IVb	PVDF 35 µm PVC 120 µm PET 55 µm Stainless steel 304 Stainless steel 304 + PVC + PET
Ai5 Aggressive environment	Intensive cleaning	High	0°C to +35°C +32° to +95°F	Cooking rooms, dryers	Vc	PVC 120 µm PET 55 µm Stainless steel 304 Stainless steel 304 + PVC + PET
Ai6 Very aggressive environment	Very intensive cleaning	Saturated	0°C to +40°C +32° to +104°F	Showers washrooms	(*)	Stainless steel 304 + PVC + PET Stainless steel 316L

Extract from DTU 45.1 – Food handling facilities

N.B. :

- The table is provided as a guide only, the classes must be appropriate to the controlled conditions of each facility.
- A single parameter could justify the selection of ambient conditions (hygrometry, cleaning frequency, chemical aggressivity, salinity)

Aggressivity criteria

- 1 – No aggressive ambient conditions: environment presenting no aggressivity due to corrosive chemical components and/or microorganisms.
- 2 – Slightly aggressive ambient conditions: environment with no aggressive ambient conditions but whose walls could occasionally be splashed with slightly aggressive liquids.
- 3 – aggressive ambient conditions: environment where acid, basic or saline acid vapours occur and/or with presence of microorganisms and/or likely to be subjected to disinfection.
- 4 – very aggressive ambient conditions: environment where acid, base or saline acid vapours or gas occur and/or with presence of microorganisms and/or frequent risk of splashing of walls and/or likely to be subjected to disinfection with aggressive products.

Cleaning criteria

- 1 – regular maintenance: this involves regular supervision and occasional cleaning (frequency from one to several years according to the use of the facility) using non-aggressive methods and resources (no pressure washing).
- 2 – non-aggressive cleaning (usually on monthly basis): cleaning performed with neutral products at temperature of 30°C 86°F and low pressure spraying of $\leq 0.3\text{Mpa}$ 6 266 lbf/sq.ft.
- 3 – intensive cleaning (usually on daily basis): cleaning performed with neutral products (ph 5 to 9) at temperature of 40°C 104°F and pressure of 3.5 Mpa 73 099 lbf/sq.ft (pressure of spray nozzle).
- 4 – very intensive cleaning (usually on daily basis): cleaning performed with occasional use of extreme pH (<math><5</math> or >9) and/or high temperature (<math><60^{\circ}\text{C}</math> 140°F) and/or high pressure washing (pressure <math><5\text{Mpa}</math> 104 430 lbf/sq.ft at output from nozzle and impact pressure <math><0.04\text{Mpa}</math> 835 lbf/sq.ft).

Humidity criteria

- 1 – humidity ambient conditions: ambient conditions are said to be «humid» where the hygrometry of the facility is high and if under the operating conditions of the facility there is a risk of condensation.
- 2 – very humid ambient conditions: ambient conditions are said to be very humid where the hygrometry of the facility is very high and if under the operating conditions of the facility the risk of condensation is frequent.
- 3 – saturated ambient conditions: ambient conditions are said to be saturated where the hygrometry of the facility is very high and if there is a permanent risk of condensation in the operating conditions of the premises.

Outdoor atmosphere

Outdoor atmospheres are classified by categories in order to comply with NF P 34-301 specifications for the selection of panel facings.

	Rural or no polluted atmosphere III	Urban or industrial atmosphere		Marine atmosphere				Specific atmosphere	
		normal III	harsh	20 to 10 km <i>12.43 to 6.22 mi</i> III	10 to 3 km <i>6.22 to 1.87 mi</i> IV	< 3 km <i>1.87 mi</i> V	mixte	high UV	special

Galvanized or coated with alloy (zinc and aluminium) steel

Polyester 25 μm <i>1mil</i>	● ●	● ●	●	● ●	-	-	-	-	●
PVDF 35 μm <i>1.3mil</i>	● ●	● ●	●	● ●	● ●	-	-	-	●

- unsuitable
- consult maker
- ● suitable

N.B.: the PET and PVC system are unsuitable for exterior use.

Technical characteristics of the supports

- z225 hot-galvanized **pre-powder coated or lined steel sheet**, mini shade s280 GD+Z, according to standard NF EN 10326, thickness 0,50 mm 0.019", 0,63 mm 0.024" or 0,75 mm 0.029"

- **Stainless steel sheet** shades, thickness 0,60 mm 0.023" or 0,80 mm 0.031"

* x5CrNi 18-10 (EN 1-4301 or AISI 304)

* x2CrNiMo17-12-2 (EN 1-4404 or AISI 316L)

- **Pre-powder coated aluminium** shade EN AW.3004 H46 according to standard EN 1396, thickness 0,67 mm 0.026"

Test types and results of various panel facings on galvanized steel sheets

	Testing standards and conditions	Polyester powder coat 25 µm	Conductive powder coat	PVDF powder coat 35 µm	PVC film 120 µm	PET 55 µm system
Category	XP P 34-301	IIIa		IVb	Vc	Vc
Gloss	ISO 2813 (ECCA-T2) incidence 60°	30 ± 6%	30 ± 6%	30 ± 6%	25%	30 ± 6%
Shock resistance	ISO 6272 (ECCA-T5)	No loss of panel face adherence				
Adherence by bending	ISO 1519 (ECCA-T7)	3t	3t	2t	0t	1t
Resistance to humidity	ISO 6270 (ECCA-T9)	≥ 1000 h	≥ 1000 h	≥ 1000 h	≥ 1000 h	≥ 1500 h
Resistance to neutral salt spray	ISO 7253 (ECCA-T8)	≥ 360 h	≥ 360 h	≥ 500 h	≥ 500 h	≥ 500 h
Chalk hardness	ISO 3270 (ECCA-T4)	H	H	HB	2H	2H
Adherence to panel face (grid pattern)	ISO 2409		Class «0»			
Panel face resistance to heat	ISO 3270 (ECCA-T13)	100 h to 80°C 176°F ΔE ≤ 0,1		100 h to 70°C 158°F ΔE ≤ 0,1	100 h to 70°C 158°F ΔE ≤ 0,1	
Resistance to abrasion	ISO 7784	40 mg	5.6 mg	30 mg	10 mg	
Reaction to fire	NF P 92-507	M0	M0	M0	M1	M0
Surface resistivity	ASTM D257	10 ¹¹ Ω/□	10 ⁷ Ω/□			

Special warning for HPL panel face

Compact laminated sheets are very sensitive to hygrometry conditions : high variation of dimensions under extreme high or low ambient humidity can occur.

For that reason, several precautions must be taken at the different production or delivery stages : HPL sheets or finished HPL panels must be stored under tight controlled ambient conditions: from 10 to 30°C 50°F to 86°F and relative humidity 40 to 60 %). Finished HPL panels should not be used under high temperature and/or high relative humidity conditions.

Storage and working conditions : The 2 sides of the HPL panels must remain aerated and within the average temperature range of 10 to 30°C 50°F to 86°F and relative humidity from 40 to 60 %.

Ignoring these warnings, bending or twisting of the HPL panels may occur.

Resistance of panel faces to chemical products

Information given as a guide only

Coatings		Polyester lacquer	Conductive lacquer	PVDF 35 µm 1.38 mils	PVC 120 µm 4.7 mils	PET 55 µm 2.16 mils	Compact laminated	Stainless steel 304 + PVC + PET	Stainless steel 304	Stainless steel 316L
Chemical products	Chemical family									
Acetone	Ketone	⊖	⊖	⊖	⊖	⊖	☺	☺	☺	☺
Acetic acid (CH ₃ COOH) (vinegar) 10%	Acid	⊖	⊖	☺	☺	☺	☺	☺	☺	☺
Hydrochloric Acid (HCl) 10%	Acid	⊖	⊖	⊖	⊖	☺	☺	✓	⊖	☺
Nitric acid (H ₂ NO ₃) 10%	Acid	⊖	⊖	☺	☺	☺	☺	☺	☺	☺
Phosphoric acid (H ₃ PO ₄) 10%	Acid	⊖	⊖	☺	☺	☺	☺	☺	☺	☺
Sulphuric acid (H ₂ SO ₄) 10%	Acid	⊖	⊖	☺	☺	☺	☺	☺	☺	☺
Ethyl alcohol - Methylated spirit	Alcohol	☺	☺	☺	☺	☺	☺	☺	☺	☺
Isopropyl alcohol	Alcohol	☺	☺	☺	☺	☺	☺	☺	☺	☺
Ammonia - NH ₄ OH	Base	⊖	⊖	☺	☺	☺	☺	☺	☺	☺
Ammonium bisulphite	Salt	☺	☺	☺	☺	☺	☺	☺	☺	☺
Buthanol	Alcohol	☺	☺	☺	☺	☺	☺	☺	☺	☺
Sodium hypochlorite - NaClO (Javel water) high concentration		⊖	⊖	⊖	⊖	☺	☺	✓	☺	☺
Therebentine	Alcohol	☺	☺	☺	☺	☺	☺	☺	☺	☺
MEK (Methyl ethyl Ketone)	Ketone	⊖	⊖	⊖	⊖	⊖	☺	⊖	☺	☺
Methanol	Alcohol	☺	☺	☺	☺	☺	☺	☺	☺	☺

Caption



Prohibited



Recommended



Suitable To be studied case by case

Resistance of panel faces to chemical products

Information given as a guide only

Coatings		Polyester lacquer	Conductive lacquer	PVDF 35 µm 1.38 mils	PVC 120 µm 4.7 mils	PET 55 µm 2.16 mils	Compact laminated	Stainless steel 304 + PVC + PET	Stainless steel 304	Stainless steel 316L
Chemical products	Chemical family									
Phenol	Alcohol	☺	☺	☺	☺	☺	☺	☺	☺	☺
Potash - Potassium hydroxide - KOH - 10%	Base	☹	☹	☺	☺	☺	☺	☺	☺	☺
Alkaline industrial soap	Base soap	☹	☹	☺	☺	☺	☺	☺	☺	☺
Chlorinated industrial soap	Neutral soap	☹	☹	☺	☺	☺	☺	☺	☺	☺
No chlorinated industrial soapé	Neutral soap	☺	☺	☺	☺	☺	☺	☺	☺	☺
Kitchen salt (Sodium chloride - NaCl)	Salt	☹	☹	☹	☹	☹	☺	☺	☺	☺
Kitchen salt + use of acidic cleaning agents	Salt + Acid	☹	☹	☹	☹	☹	☹	☑	☹	☺
Sodium hydroxide - NaOH - 10%	Base	☹	☹	☹	☺	☺	☺	☺	☺	☺

Panel face resistance to hydrogen peroxide H2O2 (oxygenated water) (fogging tests)

Materials	Pre-coated sheet - polyester 25 µm 0.98 mil - PVDF 35 µm 1.38 mil - lacquer thk. ≤ 50 µm 1.97 mil	Painted sheets - paint 50 µm 1.97 mil ≤ thk. < 80 µm 3.15 mil	Painted sheets - paint thk. ≥ 80 µm 3.15 mil	Film clad sheets (process) - PET 55 µm 2.16 mil - PVC 120 µm 4.7 mils	Compact laminated	Stainless steel 304 + PVC + PET	Untreated stainless steel 304, 316L,
Decontamination frequency							
Low	☹	☹	☑	☺	☺	☺	☺
Average	☹	☹	☑	☺	☑	☺	☺
High	☹	☹	☹	☑	☑	☑	☺

Refer to Chapter 12 – Panel face shade chart for further information.



Midnight blue
RAL 5011



Pacific blue
RAL 5010



Horizon blue
RAL 5015

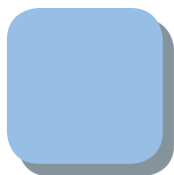

Glacier blue
Pantone 278C



Lagoon green
RAL 6027



Meadow green
RAL 6018



Forest green
RAL 6029



Sulphur yellow
RAL 1016



Pale orange
Pantone 1495



Bright pink
RAL 3015



Molten red
RAL 3020



Canyon red
RAL 3013



Storm grey
RAL 7040



Pebble white
RAL 9002



Iceberg white
RAL 9010

Ours colours are close to RAL and Pantone references.