

Acoustic LM partition

Metal facings and rock wool core

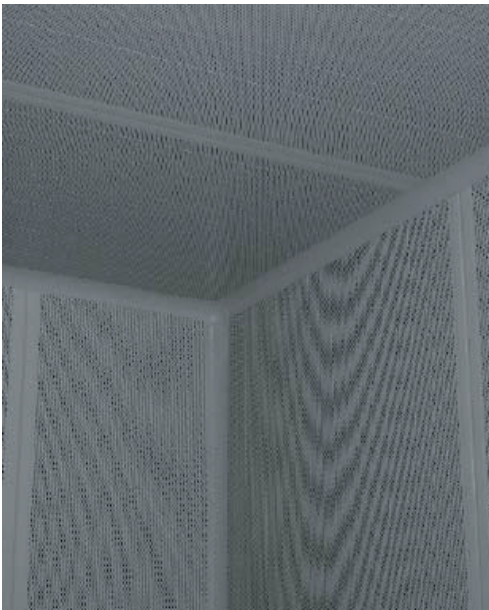

The acoustic LM partition allows the treatment of all industrial acoustic problems while keeping its thermal properties. The sound reduction is enhanced and the perforation allows to obtain a good acoustic absorption index.

Rw (C;Ctr) = 31 (-2;-4) dB / $\alpha_w = 1$
Rw (C;Ctr) = 32 (-2;-4) dB / $\alpha_w = 0,95$

Design

The acoustic LM partition consists of LM panels with one perforated face.

The easiness and rapidity of assembly, adaptation to architecture and the possibility of later transformation are its major advantages compared with traditional structures.

Technical characteristics

Single width : 116 mm

Panels	LM 60	LM 80
Thicknesses mm	60 2.36"	80 3.15"
Maxi length cm	600 19.7'	600 19.7'
Uc	0.621 W/m ² .K 0.109 Btu/h.ft ² .°F	0.477 W/m ² .K 0.084 Btu/h.ft ² .°F

Facings

On 1 side, perforated galvanised steel sheet Z225 (225g/m² of zinc) of thickness 6/10th, smooth or lightly ribbed, (rib depth 0,6 mm 0.02") coated with polyester lacquer 25 µm, lined inside with a fibreglass.

On the other side galvanised steel sheet Z225 (225g/m² of zinc), of thickness 8/10th lightly ribbed, (rib depth 0,6 mm 0.02"), or smooth, coated with polyester lacquer 25 µm.

Standard colour : iceberg white (near RAL 9010).

Acoustic LM partition

Metal facings and rock wool core

Installation

Assembly

The junction between panels is made by connection metal to metal avoiding.



Acoustic performances

Sound reduction index according to the standard NF-EN ISO 717-1 :

panel of thickness 60 mm : $R_w (C;Ctr) = 31 (-2;-4)$ dB

panel of thickness 80 mm : $R_w (C;Ctr) = 32 (-2;-4)$ dB

Acoustic absorption index according to the standard NF EN ISO 11654 :

panel of thickness 60 mm : $\alpha_w = 1$ () (mineral wool density 120 Kg/m^3 7.5 lb/ft^3)

panel of thickness 80 mm : $\alpha_w = 0,95$ () (mineral wool density 135 Kg/m^3 8.4 lb/ft^3)

Partition LM

Metallic facings and mineral wool core

Technical characteristics

Panels

Thicknesses		60 mm 2.36"	80 mm 3.15"	100 mm 3.94"
Dimensions	Width	1,16 m 3.8'		
	Maxi lengths	6,00 m 19.7'	7,00 m 23'	8,00 m 26.2'
Thermal conductivity coefficient		$\lambda = 0,041 \text{ W/m} \cdot ^\circ\text{C}$ 0.024 Btu.ft/h.ft ² .°F		
Thermal transmission coefficient		$U_c = 0,61 \text{ W/m}^2 \cdot ^\circ\text{C}$ 0.11 Btu/h.ft ² .°F	$U_c = 0,47 \text{ W/m}^2 \cdot ^\circ\text{C}$ 0.08 Btu/h.ft ² .°F	$U_c = 0,38 \text{ W/m}^2 \cdot ^\circ\text{C}$ 0.07 Btu/h.ft ² .°F
R-value		9	12	15
Weight (2 faces 0,6 mm)		16 kg/m ² 3.3 lbs/sq.ft	18 kg/m ² 3.7 lbs/sq.ft	20 kg/m ² 4.1 lbs/sq.ft
Tightness in whole partition with silicon joint		$Q_s \leq 0,0027 \text{ m}^3/\text{h} \cdot \text{m}^2$ 0.0088 ft ³ /h.ft ² under $\Delta P = 50 \text{ Pa}$ 0.007 PSI		

Maximum acceptable loads in partition

Bending resistance, panels on 2 or 3 supports (Load (q) in daN/m²)

	Partition height (m)	3,00 9.8'	4,00 13.1'	5,00 16.4'	6,00 19.7'	7,00 23'	8,00 26.2'
2 supports	LM60	55 11.5 lbf/ft ²	30 6.3 lbf/ft ²	-	-	-	-
	LM80	65 13.6 lbf/ft ²	40 8.4 lbf/ft ²	25 5.22 lbf/ft ²	-	-	-
	LM100	80 16.7 lbf/ft ²	45 19.4 lbf/ft ²	30 6.3 lbf/ft ²	20 4.2 lbf/ft ²	-	-
3 supports	LM60	130 27.2 lbf/ft ²			90 18.8 lbf/ft ²	-	-
	LM80	-	130 27.2 lbf/ft ²		100 20.9 lbf/ft ²	55 11.5 lbf/ft ²	-
	LM100	-	150 31.3 lbf/ft ²		110 22.9 lbf/ft ²	60 12.5 lbf/ft ²	-

Installation

Assembly

The panels are assembled by double fitting sheet / sheet.

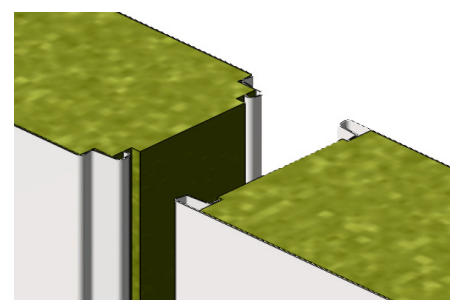

Assembly between panels

Tightness

- Silicon sealant (quality-label SNJF ; complies with FDA 21 CFR 175.105)
- Flexible sealant with closed reticulate polyethylene cells, density 50 kg/m³ 3.1 lb/ft³, as adhesive strips (ceiling upper face)

Reports and approvals

Fire reaction : Euroclasses = A2-s1,d0

FM Global : FM Approvals (Standard 4880) = Class 1

Acoustic performances :

Sound reduction index according to the standard NF-EN ISO 717-1 : panel of thickness 60 mm : $R_w (C;Ctr) = 29 (-3;-5) \text{ dB}$

Consult the data n°0112 «Reports and approvals».

Semi flush glazing

GSP-0310-E/B



Offered in two alternatives, the semi flush glazing consists of a glazing set, in factory or on site, into an white (close to RAL 9010) aluminium frame. The finishing semi flush profiles are clipped on site.

Application

This glazing is used in controlled environment rooms, without any temperature or humidity restrictions.

Characteristics

Variant 1 : 1 single glass thickness 44-1 semi flush on one face of the panel, thickness 60 mm 2.36", 80 mm 3.15" or 100 mm 3.94"

Variant 2 : 2 single glasses thickness 44-1 semi flush on the 2 faces of the panel, thickness 60 mm 2.36", adaptable on panels of thickness 80 mm 3.15" and 100 mm 3.94".

variant 1

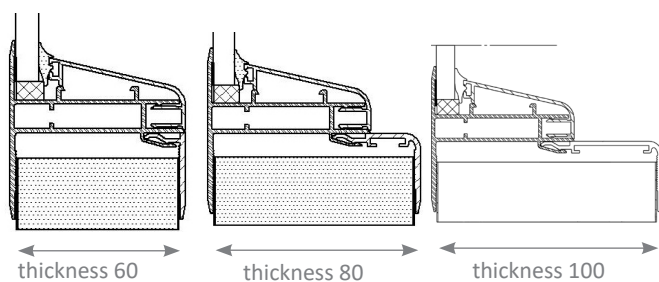

variant 2

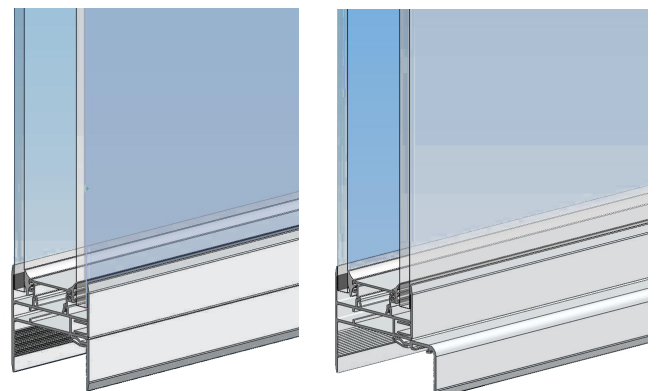
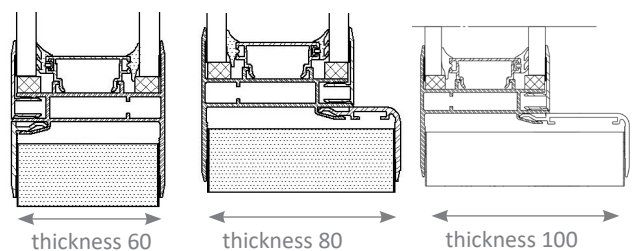

Standards dimensions

dimensions	800 mm 2.62'	1000 mm 3.28'	1200 mm 3.94'
800 mm 2.62'	•	•	•
1000 mm 3.28'	•	•	•
1200 mm 3.94'	•	•	•

Specific dimensions on request (maximum surface 2 m² 21.5 sq.ft).

Variant with integrated blind only for double glazings

It is possible to integrate white Venetian blinds, manuals or automatics, and adjustable.

In manual control with rod or thin cord.

In automatic, control with remote control or button.



Semi flush door sheet leaf 60 2.36''

Semi flush frame for panels 60 mm 2.36'', 80 mm 3.15'' ou 100 mm 3.94''

GSP-0313-E/B



Service door with semi flush frame on the 2 faces of the partition.
The leaf consists of an aluminium honey comb or a mineral wool core bonded between two metallic facings.

Technical characteristics

Leaf

- 1 or 2 leaves of thickness 60 mm 2.36''
- sandwich structure
- aluminium honey comb or mineral wool core and aluminium structure profiles
- smooth galvanised steel sheet 8/10th not welded and heat-cured epoxy-polyester powder paint, iceberg white (close to RAL 9010), options : colour according to the chart (GSP-1208)
- mono component polyurethane glue

Door frame

- one piece semi flush frame for panels of thickness 60 mm 2.36'', 80 mm 3.15'' or 100 mm 3.94''
- frame in aluminium alloy 6060 T5 (standard NF EN 573)

Tightness

- seal on 3 sides

	standards equipment	options	see data N°	
doors with 1 or 2 leaves	adjustable white lacquered aluminium hinges	adjustable stainless steel finishing aluminium hinges	GSP-0803-E/B	
		stainless steel hinges (no adjustable)		
	white PVC handle with cylinder-type safety lock (single keyway)	coloured PVC handle with european profile lock (single keyway)	GSP-0801-E/B	
		stainless steel handle with european profile lock (single keyway)		
		white PVC pull handle (without lock) with push plate		
		stainless steel pull handle (without lock) with push plate		
	stamped stainless steel strike			
	doors with 1 or 2 leaves	panic push bar		GSP-0803-E/B
			floor gasket	GSP-0806-E/B
			sweeper gasket	
		push plate		
		wall mounting door closer	GSP-0804-E/B	
		double flush vision panel 640 x 350 mm 2.1' x 1.15', 800 x 500 mm 2.6' x 1.6', 1000 x 500 mm 3.3' x 1.6'	GSP-0820-E/B	
grey PVC kick plate, height 850 mm 2.8' on 1 or 2 faces		GSP-0811-F/B		
stainless steel sheet kick plate, height 850 mm 2.8' on 1 or 2 faces		GSP-0812-F/B		
closure detection contact		GSP-0814-E/B to GSP-0819-E/B		
wall mounting magnetic lock				
airlock management				
doors with 2 leaves	lever bolt top and bottom on half fixed leaf		GSP-0807-E/B	
	closing selector		GSP-0804-E/B	

Semi flush door sheet leaf 60 2.36''

Semi flush frame for panels 60 mm 2.36'', 80 mm 3.15'' ou 100 mm 3.94''

GSP-0313-E/B

Dimensions

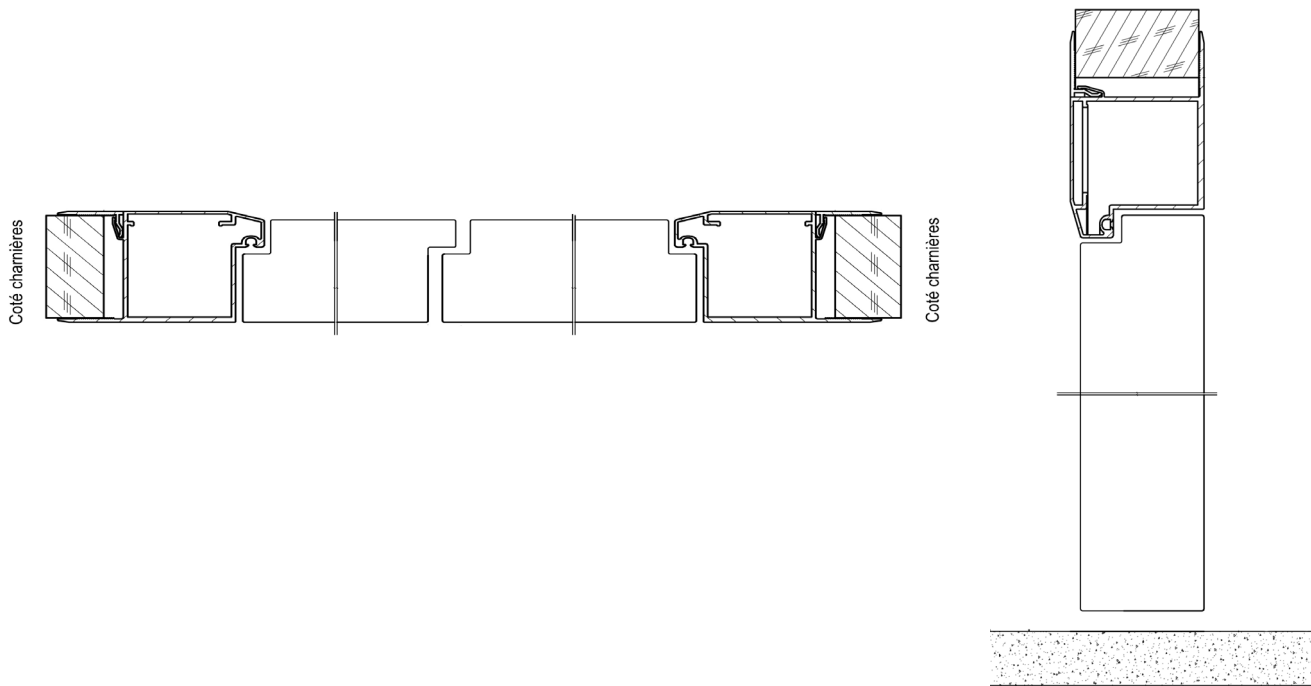

mm	designation H x W	clear opening H x W	door frame H x W	designation H x W	clear opening H x W	door frame H x W	designation H x W	clear opening H x W	door frame H x W
1 leaf	2040 x 630 80''x 25''	2039 x 609 80''x 24''	2139,5 x 810 84''x 31''	2240 x 630 88''x 25''	2239 x 609 88''x 24''	2339,5 x 810 92''x 31''			
	2040 x 830 80''x 33''	2039 x 809 80''x 32''	2139,5 x 1010 84''x 40''	2240 x 830 88''x 33''	2239 x 809 88''x 32''	2339,5 x 1010 92''x 40''			
	2040 x 930 80''x 37''	2039 x 909 80''x 36''	2139,5 x 1110 84''x 44''	2240 x 930 88''x 37''	2239 x 909 88''x 36''	2339,5 x 1110 92''x 44''	2440 x 930 96''x 37''	2439 x 909 96''x 36''	2539,5 x 1110 100''x 44''
	2040 x 1030 80''x 41''	2039 x 1009 80''x 40''	2139,5 x 1210 84''x 48''	2240 x 1030 88''x 41''	2239 x 1009 88''x 40''	2339,5 x 1210 92''x 48''	2440 x 1030 96''x 41''	2439 x 1009 96''x 40''	2539,5 x 1210 100''x 48''
	2040 x 1130 80''x 45''	2039 x 1109 80''x 44''	2139,5 x 1310 84''x 51''						
2 leaves	2040 x 1260 80''x 50''	2039 x 1244 80''x 49''	2139,5 x 1445 84''x 57''	2240 x 1260 88''x 50''	2239 x 1244 88''x 49''	2339,5 x 1445 92''x 57''			
	2040 x 1460 80''x 58''	2039 x 1444 80''x 57''	2139,5 x 1645 84''x 65''						
	2040 x 1660 80''x 65''	2039 x 1644 80''x 65''	2139,5 x 1845 84''x 73''	2240 x 1660 88''x 65''	2239 x 1644 88''x 65''	2339,5 x 1845 92''x 73''	2440 x 1660 96''x 65''	2439 x 1644 96''x 65''	2539,5 x 1845 100''x 73''
	2040 x 1860 80''x 73''	2039 x 1844 80''x 73''	2139,5 x 2045 84''x 80''						
	2040 x 2060 80''x 81''	2039 x 2044 80''x 80''	2139,5 x 2245 84''x 88''	2240 x 2060 88''x 81''	2239 x 2044 88''x 80''	2339,5 x 2245 92''x 88''	2440 x 2060 96''x 81''	2439 x 2044 96''x 80''	2539,5 x 2245 100''x 88''
	2040 x 2260 80''x 89''	2039 x 2244 80''x 88''	2139,5 x 2445 84''x 96''	2240 x 2260 88''x 89''	2239 x 2244 88''x 88''	2339,5 x 2445 92''x 96''	2440 x 2260 96''x 89''	2439 x 2244 96''x 88''	2539,5 x 2445 100''x 96''

Link with floor

By means of an adjustable metallic belt only for SG panels

The adjustable metallic belt enables the level to be precisely adjusted while providing for a 5 mm 0.2" undercut here and there to enable the floor to be flush with the partition.

Plinth accessories (end-pieces, inside and outside angle trims) provide an excellent finish.

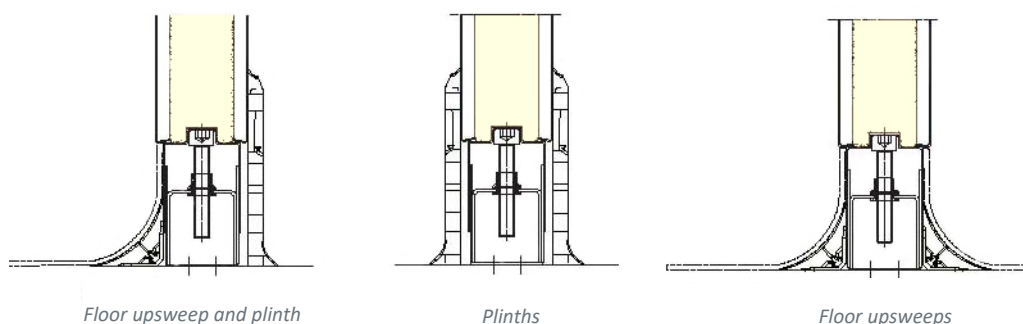
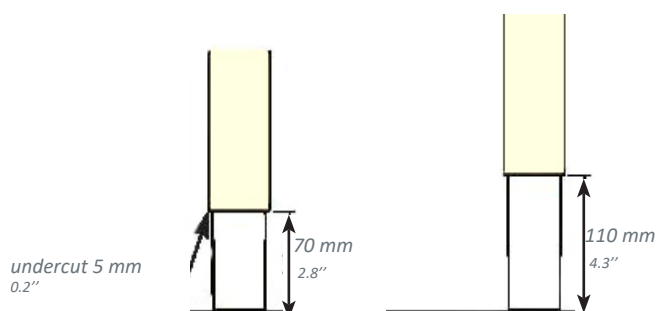

By U-shaped profile to the floor

Partitions are fastened to the floor by U-shaped PVC or metallic profile.

Protection by plinth for both walls.

It is set directly on the even, level and finished floor with shim if necessary in the U-shaped profile.

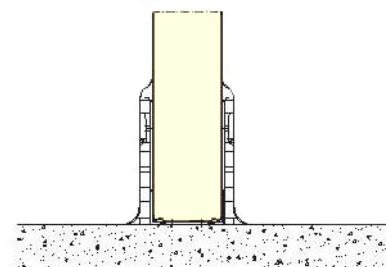

Partition fixings

The maximum height allowed for partitions made up of a single panel is 6 m 19.7' and 60 mm 2.36" thick. Above this height, or in certain precise cases (especially facades), the partitions must be stabilized with horizontal bars (case by case study).

Several solutions are available for securing the vertical partition to the frame of the existing building :

- **Fixing on insert (SG panels)**. An insert is sunk in the panel during manufacture. Therefore, no drilling of the panel occurs and there is no consequent thermal bridge. The diagrams below illustrate the various fixing methods.

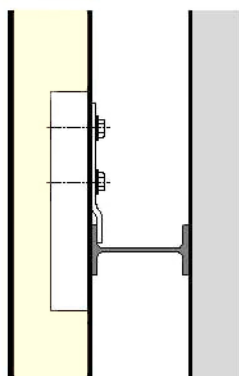

Clamp fixing

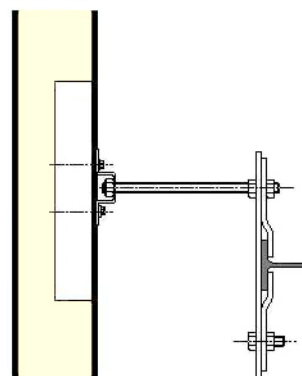

Hitch and flat flange

- **Fixing by through mounting**. Specific sleeves enable through fixing with «thermal breakdown» or through screws.

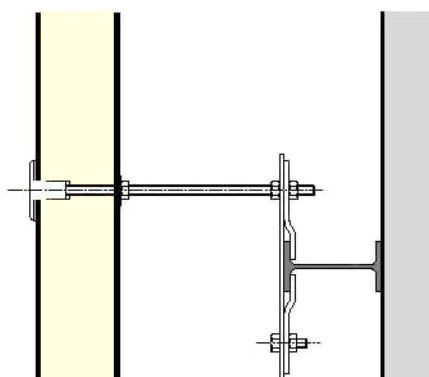

Fixing with sleeves

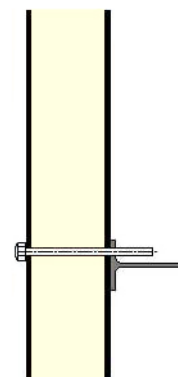

Fixing with through screws

Junction between vertical panels

Partition to partition junction in corner

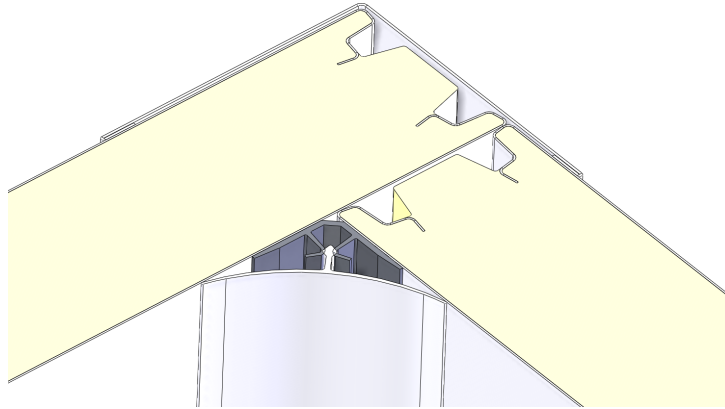

Panel to panel junctions

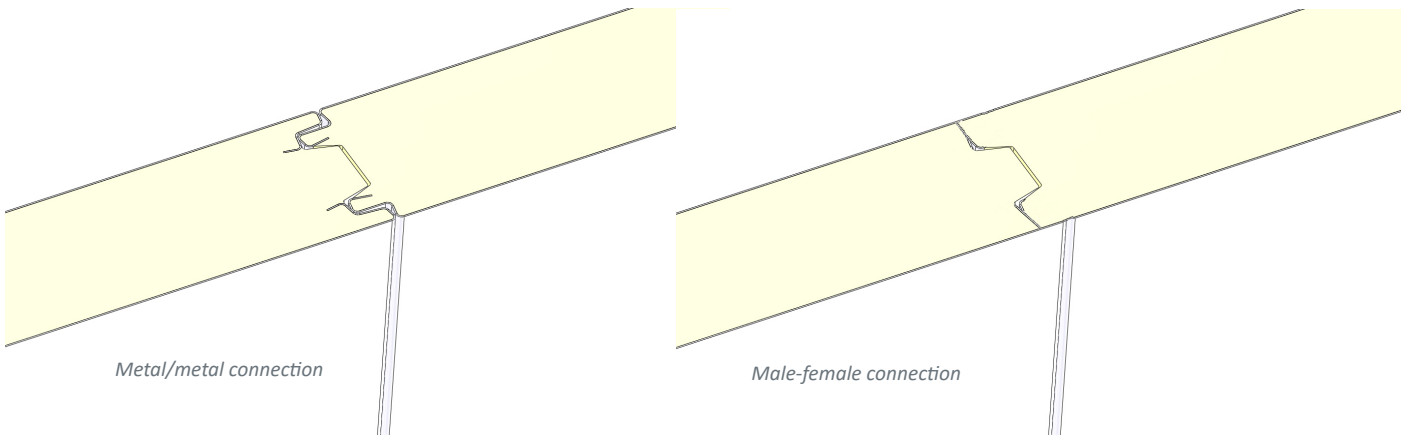

Ceiling to partition junction

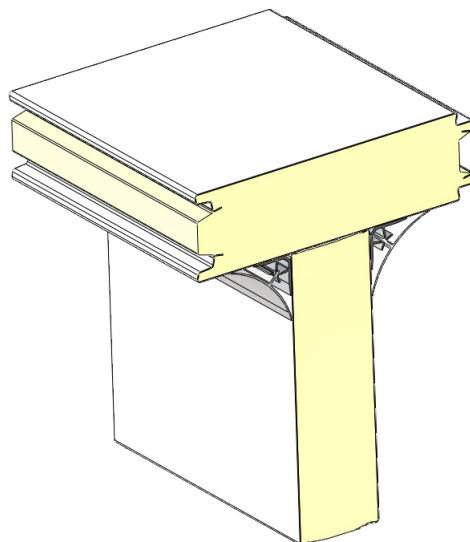

Tight sliding door on semi flush frame

Semi flush frame for panels of thickness 60 mm 2.36", leaf 40 mm 1.57" aluminium honey comb core

GSP-0318-E/A



The leaf consists of aluminium honeycomb core bonded between 2 metallic facings.

Sliding system with ramps and tightness on the 4 sides.

Door easy to clean for an use in all clean rooms.

Technical characteristics

Leaf

- 1 leaf of thickness 40 mm 1.57"
- sandwich structure with a reinforced frame integrated
- aluminium honey comb core
- facing (colour according to the chart) : smooth galvanised steel sheet 6/10th and painted with epoxy-polyester powder, heat-cured.
- mono component polyurethane glue

Option :

- door with 2 leaves
- automatism

Door frame

- semi flush one-piece frame for panels of thickness 60 mm 2.36"
- galvanised steel Z225 frame, heat-cured epoxy-polyester powder coating.

Left or right opening.

Tightness

- airtight peripheral joint on the 4 sides

Sliding system:

The manual system consists in a track fixed directly on the frame with integrated ramps and butts.

Aluminium track cover, easy to clean and designed to receive, without modification, an automatism.

White colour close to RAL 9010.

	standards equipment	options	see data N°
door with 1 leaf	aluminium pull handle outside recessed pull handle inside	stainless steel pull handle (without lock) on external side	GSP-0908-E/A
	anodized aluminium track with lacquered aluminium cover track		
	bottom door guides		
		double flush vision panel 640 x 350 mm 2.1' x 1.15', 800 x 500 mm 2.6' x 1.6', 1000 x 500 mm 3.3' x 1.6'	GSP-0920-E/A
		grey PVC kick plate, height 850 mm 2.8' on 1 or 2 faces	GSP-0911-E/B
		stainless steel sheet kick plate, height 850 mm 2.8' on 1 or 2 faces	GSP-0912-E/B
		automatism	GSP-0910-E/A
		electric bolt	GSP-0913-E/A

Tight sliding door on semi flush frame

Semi flush frame for panels of thickness 60 mm 2.36", leaf 40 mm 1.57" aluminium honey comb core

GSP-0318-E/A

Dimensions

(mm)	clear opening H x W	overall H x W	clear opening H x W	overall H x W	clear opening H x W	overall H x W
1 leaf	2000 x 950 78" x 37"	2345 x 2118 92" x 83"	2200 x 950 86" x 37"	2545 x 2118 100" x 83"	2400 x 950 94" x 37"	2745 x 2118 108" x 83"
	2000 x 1200 78" x 47"	2345 x 2618 92" x 103"	2200 x 1200 86" x 47"	2545 x 2618 100" x 103"	2400 x 1200 94" x 47"	2745 x 2618 108" x 103"
	2000 x 1400 78" x 55"	2345 x 3018 92" x 119"	2200 x 1400 86" x 55"	2545 x 3018 100" x 119"	2400 x 1400 94" x 55"	2745 x 3018 108" x 119"
	2000 x 1600 78" x 63"	2345 x 3418 92" x 134"	2200 x 1600 86" x 63"	2545 x 3418 100" x 134"	2400 x 1600 94" x 63"	2745 x 3418 108" x 134"
	2000 x 1800 78" x 70"	2345 x 3818 92" x 150"	2200 x 1800 86" x 70"	2545 x 3818 100" x 150"	2400 x 1800 94" x 70"	2745 x 3818 108" x 150"
	2000 x 2000 78" x 78"	2345 x 4218 92" x 166"	2200 x 2000 86" x 78"	2545 x 4218 100" x 166"	2400 x 2000 94" x 78"	2745 x 4218 108" x 166"

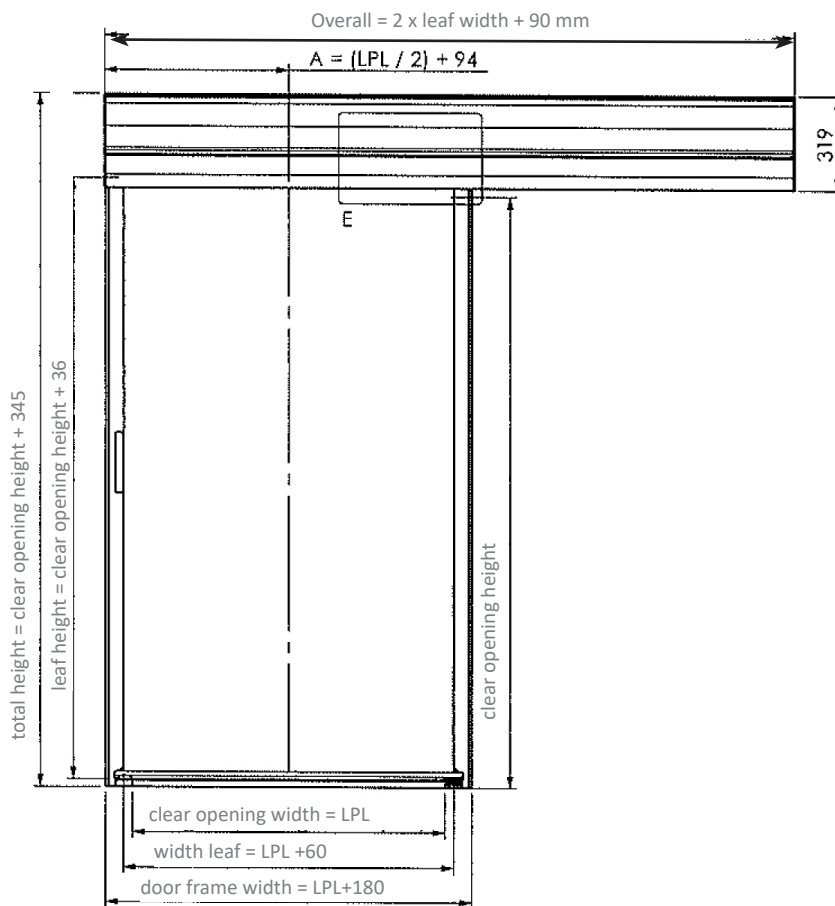

bottom guides easily washable



Thin and easy to clean rail cover



gasket easily washable

Tight sliding door on semi flush frame

Semi flush frame for panels of thickness 60 mm 2.36", leaf 40 mm 1.57" aluminium honey comb core

GSP-0318-E/A

Permeability

The air permeability of the sliding doors has been measured and recorded in CETIAT test report N°1014119.

Permeability of a sliding door in m³/h depending on pressure or depression.

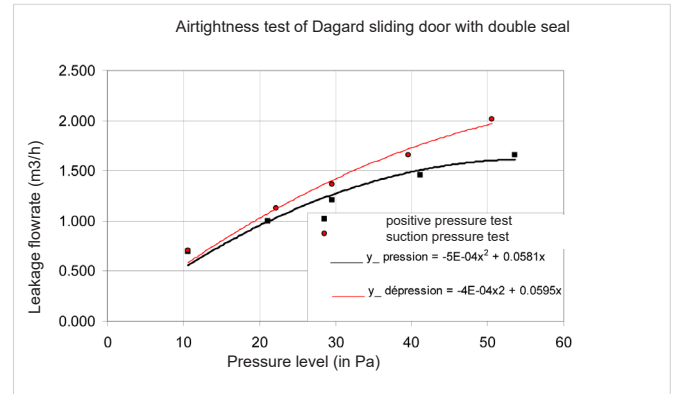
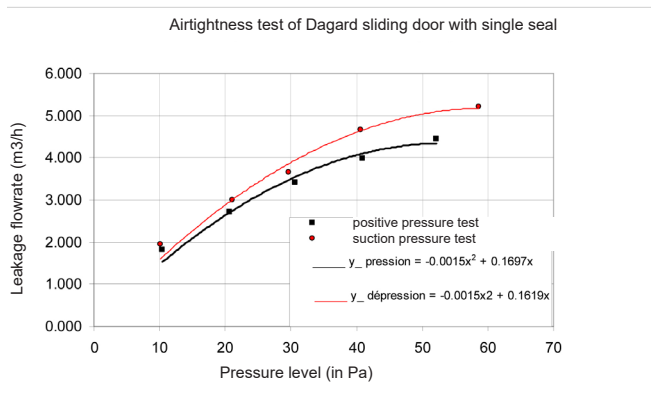

Nota :

- a door is under pressure when the action of the air tends to stick the leaf on the door frame
- a door is in vacuum when the action of the air tends to spread the leaf of the door frame

Use recommendation

Automatic tight sliding doors don't comply the CO48 regulation, requiring an automatic opening, in case of lack of power, by an independent mechanical solution.

We propose as, an option, an opening by safety battery.

Acoustic LM ceiling

Metal facings and rock wool core

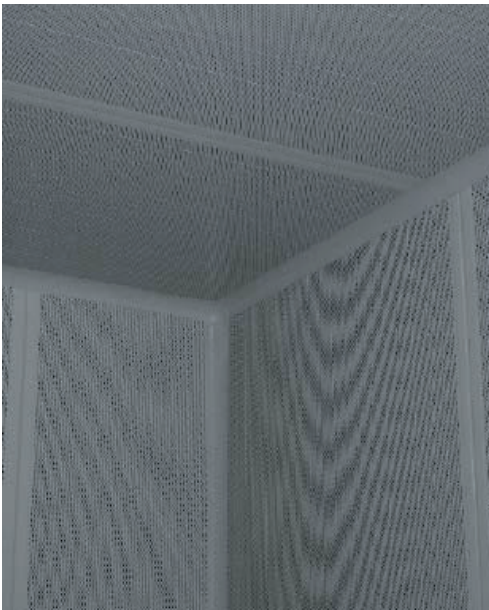

The acoustic LM ceiling allows to treat all industrial acoustic problems while keeping its thermal properties.

The sound reduction is enhanced and the perforation allows to obtain a good acoustic absorption index.

Rw (C;Ctr) = 31 (-2;-4) dB / $\alpha_w = 1$
Rw (C;Ctr) = 32 (-2;-4) dB / $\alpha_w = 0,95$

Design

The acoustic LM α ceiling consists of LM panels with one perforated face.

The easiness and rapidity of assembly, adaptation to architecture and the possibility of later transformation are its major advantages compared with traditional structures.

Technical characteristics

Single width : 116 mm 4.6''

Panels	LM 60	LM 80
Thicknesses mm	60 2.36''	80 3.15''
Maxi length cm	600 19.7'	600 19.7'
Uc	0.621 W/m ² .K 0.109 Btu/h.ft ² .°F	0.477 W/m ² .K 0.084 Btu/h.ft ² .°F

Facings

On 1 side, perforated galvanised steel sheet Z225 (225g/m² of zinc) of thickness 6/10th, smooth or lightly ribbed, (rib depth 0,6 mm 0.02'') coated with polyester lacquer 25 μ m, lined inside with a fibreglass.

On the other side galvanised steel sheet Z225 (225g/m² of zinc), of thickness 8/10th lightly ribbed, (rib depth 0,6 mm 0.02''), or smooth, coated with polyester lacquer 25 μ m.

Standard colour : iceberg white (near RAL 9010).

Installation

Assembly

The junction between panels is made by connection metal to metal avoiding.



Ceiling suspended to the building

The ceiling is suspended under a slab, under the main framework of the building or under the second framework.

For LM panels, the ceiling fixings are supporting T-profiles.

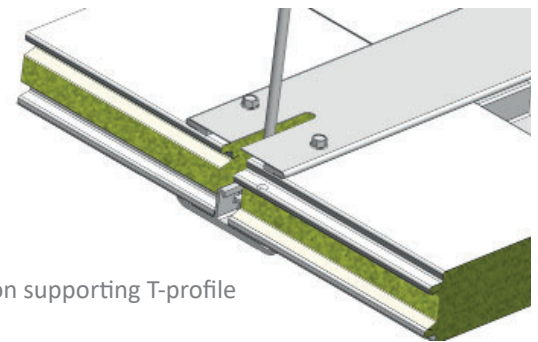

LM ceiling on supporting T-profile

Acoustic performances

Sound reduction index according to the standard NF-EN ISO 717-1 :

panel of thickness 60 mm : $R_w (C;Ctr) = 31 (-2;-4)$ dB

panel of thickness 80 mm : $R_w (C;Ctr) = 32 (-2;-4)$ dB

Acoustic absorption index according to the standard NF EN ISO 11654 :

panel of thickness 60 mm : $\alpha_w = 1$ () (mineral wool density 120 Kg/m^3 7.5 lb/ft^3)

panel of thickness 80 mm : $\alpha_w = 0,95$ () (mineral wool density 135 Kg/m^3 8.4 lb/ft^3)

Ceiling fixings

Ceilings cannot be used as walkways but they are accessible for minimum maintenance. They enable a load of 150 daN 337.2 lbf at any point, i.e.: the weight of a man holding a tool case.

Ceiling panels generally rest on the vertical partitions and/or are suspended from a wire mesh frame which depends on ceiling accessibility, the size and frequency of openings for accessories.

The suspension frame is usually 2,40 x 1,20 m 7.9' x 3.9'.

Openings exceeding 600 mm 23.6" must be strengthened by joists or additional bracket systems.

- when the maximum width of the clean room is \leq à 2.40 m 7.9', the ceiling rests on the walls.
- when the width of the room is greater than the span of ceiling panels, 2 types of frames are available to make the ceiling self-supporting:

- Omega frame
- mesh wire frame.

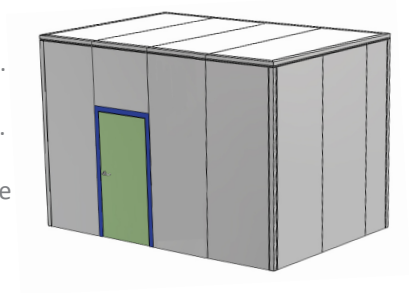

Ceiling secured by «Omega» fitting

Principle: Setting up of Omega fitting perpendicular or parallel to right of sealants.

The center distance between profile is according to the acceptable span of panels (limited at 2,40 m 7.9') or by the Omega capacity.

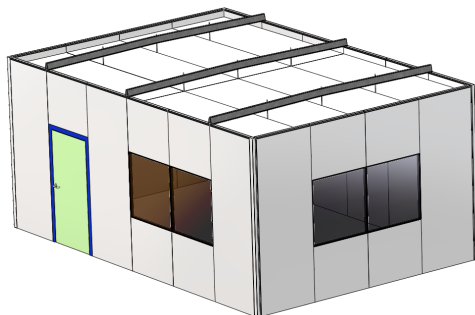

Omega height = 120 mm
4.7" or 170 mm 6.7"

View of construction with suspension by Omega



Repartition piece

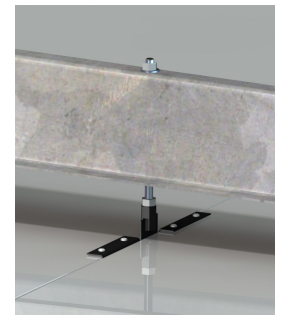

Panel fixing to the Omega

Omega span	Omega height 120 mm 4.7" thickness 3 mm 0.11" $I = 154 \text{ cm}^4$ $I/v = 25 \text{ cm}^3$ maxi length = 6 m 19.7'	Omega height 170 mm 6.7" thickness 3 mm 0.11" $I = 392 \text{ cm}^4$ $I/v = 44 \text{ cm}^3$ maxi length = 7 m 23'
	Maximum centre distance between Omegas	Maximum centre distance between Omegas
until 4 m 13.1'	2,40 m 7.9'	2,40 m 7.9'
4,40 m 14.4'	2,00 m 6.6'	2,40 m 7.9'
4,80 m 15.7'	1,50 m 4.9'	2,40 m 7.9'
5,20 m 17'	1,20 m 3.9'	2,40 m 7.9'
5,60 m 18.4'	1,20 m 3.9'	2,20 m 7.2'
6,00 m 19.7'	1 m 3.3'	1,80 m 5.9'
6,50 m 21.3'	-	1,40 m 4.6'
7 m 23'	-	1,20 m 3.9'

Base of calculation : Without clear elements, take into account

Uniformed load : 80 kg/m²

Safe deflection : 1/200th of span

Ceiling with mesh wire frame

Principle: Setting up of supporting mesh wire frames, braced together (at least 2) to make the ceiling self-supporting. The center distance between the frame elements is function of the acceptable span of panels (limited at 2,40 m 7.87') or the frame elements capacity.

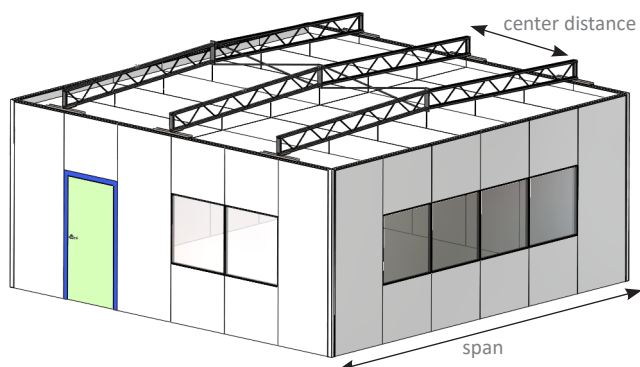

View of a construction with secured to supporting frame



Repartition piece



Fixing panel to frame

Framework height = 320 mm 12.6"

Frame length	Maximum center distance between frameworks	Frame length	Maximum center distance between frameworks
6,40 m 21'	2,40 m 7.9'	10,80 m 35.4'	2,20 m 7.2'
6,80 m 22.3'	2,40 m 7.9'	11,20 m 36.7'	2,00 m 6.6'
7,20 m 23.6'	2,40 m 7.9'	11,60 m 38.1'	1,80 m 5.9'
7,60 m 24.9'	2,40 m 7.9'	12,00 m 39.4'	1,70 m 5.6'
8,00 m 26.2'	2,40 m 7.9'	12,40 m 40.7'	1,50 m 4.9'
8,40 m 27.6'	2,40 m 7.9'	12,80 m 42'	1,40 m 4.6'
8,80 m 28.9'	2,40 m 7.9'	13,20 m 43.3'	1,25 m 4.1'
9,20 m 30.2'	2,40 m 7.9'	13,60 m 44.6'	1,15 m 3.8'
9,60 m 31.5'	2,40 m 7.9'	14,00 m 45.9'	1 m 3.3'
10,00 m 32.8'	2,40 m 7.9'		
10,40 m 34.1'	2,40 m 7.9'		

Base of calculation: Without clear elements, take into account

Uniformed load : 80 kg/m²

Safe deflection : 1/200th of span

Ceiling suspended from building

The ceiling is suspended under a concrete floor, under the main framework of the building or under a secondary framework. Fixing is assured by inserts on SG panels and by supporting T-piece for LG and LM panels.

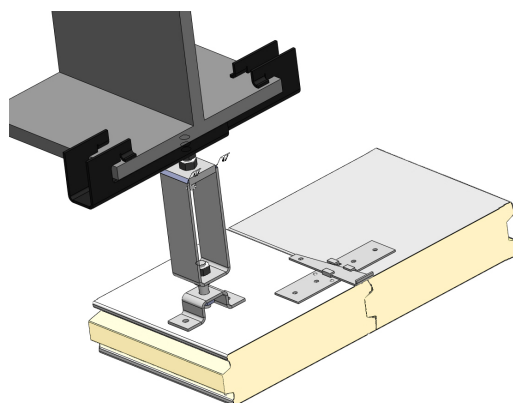

Fixing under concrete slab

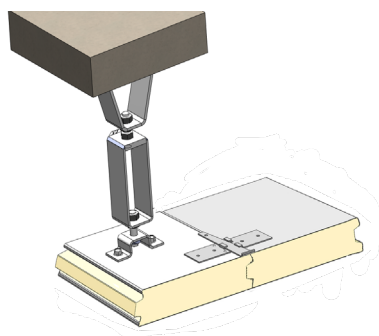

Ceiling on supporting T-profile

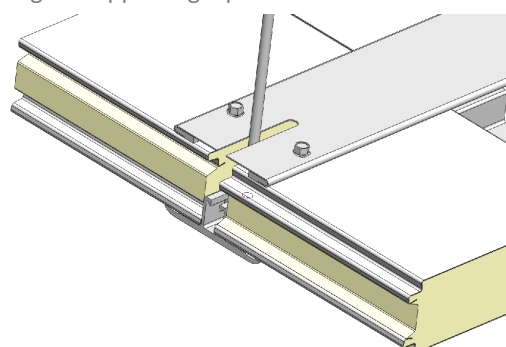

You must define your project indoor and the outdoor type of atmosphere in order to select the most appropriate types of panel facings.

Indoor atmosphere

With no clean room specific data, we have to reply on food and food processing industries classification for metallic panel facing types.

Aggressivity	Cleaning	Hygrometry	Temperature	Examples	Minimum category of appropriate coatings (NF P34.301)	Recommended coatings
Ai 1 Non-aggressive environment	Regular maintenance	Low	-40°C to +25°C -40° to +77°F	Storage of wrapped dry products	I	Polyester 25 µm PVDF 35 µm PVC 120 µm PET 55 µm Stainless steel 304 Stainless steel 304 + PVC + PET
Ai 2 Non-aggressive environment	Regular maintenance	Average	0°C to +25°C +32° to +77°F	Storage in controlled atmosphere	II	
Ai3 Non-aggressive environment	No Intensive cleaning	High	0°C to +25°C +32° to +77°F	Storage, processing moist ambient	IIIa	
Ai4 Slightly aggressive environment	No Intensive cleaning	High	0°C to +30°C +32° to +86°F	Preparation of pre-cooked foods	IVb	PVDF 35 µm PVC 120 µm PET 55 µm Stainless steel 304 Stainless steel 304 + PVC + PET
Ai5 Aggressive environment	Intensive cleaning	High	0°C to +35°C +32° to +95°F	Cooking rooms, dryers	Vc	PVC 120 µm PET 55 µm Stainless steel 304 Stainless steel 304 + PVC + PET
Ai6 Very aggressive environment	Very intensive cleaning	Saturated	0°C to +40°C +32° to +104°F	Showers washrooms	(*)	Stainless steel 304 + PVC + PET Stainless steel 316L

Extract from DTU 45.1 – Food handling facilities

N.B. :

- The table is provided as a guide only, the classes must be appropriate to the controlled conditions of each facility.
- A single parameter could justify the selection of ambient conditions (hygrometry, cleaning frequency, chemical aggressivity, salinity)

Aggressivity criteria

- 1 – No aggressive ambient conditions: environment presenting no aggressivity due to corrosive chemical components and/or microorganisms.
- 2 – Slightly aggressive ambient conditions: environment with no aggressive ambient conditions but whose walls could occasionally be splashed with slightly aggressive liquids.
- 3 – aggressive ambient conditions: environment where acid, basic or saline acid vapours occur and/or with presence of microorganisms and/or likely to be subjected to disinfection.
- 4 – very aggressive ambient conditions: environment where acid, base or saline acid vapours or gas occur and/or with presence of microorganisms and/or frequent risk of splashing of walls and/or likely to be subjected to disinfection with aggressive products.

Cleaning criteria

- 1 – regular maintenance: this involves regular supervision and occasional cleaning (frequency from one to several years according to the use of the facility) using non-aggressive methods and resources (no pressure washing).
- 2 – non-aggressive cleaning (usually on monthly basis): cleaning performed with neutral products at temperature of $< 30^{\circ}\text{C}$ 86°F and low pressure spraying of $\leq 0.3\text{Mpa}$ $6\ 266\ \text{lbf/sq.ft.}$
- 3 – intensive cleaning (usually on daily basis): cleaning performed with neutral products (ph 5 to 9) at temperature of $< 40^{\circ}\text{C}$ 104°F and pressure of $3.5\ \text{Mpa}$ $73\ 099\ \text{lbf/sq.ft.}$ (pressure of spray nozzle).
- 4 – very intensive cleaning (usually on daily basis): cleaning performed with occasional use of extreme pH (< 5 or > 9) and/or high temperature ($< 60^{\circ}\text{C}$ 140°F) and/or high pressure washing (pressure $< 5\text{Mpa}$ $104\ 430\ \text{lbf/sq.ft.}$ at output from nozzle and impact pressure $< 0.04\text{Mpa}$ $835\ \text{lbf/sq.ft.}$).

Humidity criteria

- 1 – humidity ambient conditions: ambient conditions are said to be «humid» where the hygrometry of the facility is high and if under the operating conditions of the facility there is a risk of condensation.
- 2 – very humid ambient conditions: ambient conditions are said to be very humid where the hygrometry of the facility is very high and if under the operating conditions of the facility the risk of condensation is frequent.
- 3 – saturated ambient conditions: ambient conditions are said to be saturated where the hygrometry of the facility is very high and if there is a permanent risk of condensation in the operating conditions of the premises.

Outdoor atmosphere

Outdoor atmospheres are classified by categories in order to comply with NF P 34-301 specifications for the selection of panel facings.

	Rural or no polluted atmosphere III	Urban or industrial atmosphere		Marine atmosphere				Specific atmosphere	
		normal III	harsh	20 to 10 km <i>12.43 to 6.22 mi</i> III	10 to 3 km <i>6.22 to 1.87 mi</i> IV	< 3 km <i>1.87 mi</i> V	mixte	high UV	special

Galvanized or coated with alloy (zinc and aluminium) steel

Polyester 25 μm <i>1mil</i>	● ●	● ●	●	● ●	-	-	-	-	●
PVDF 35 μm <i>1.3mil</i>	● ●	● ●	●	● ●	● ●	-	-	-	●

- unsuitable
- consult maker
- ● suitable

N.B.: the PET and PVC system are unsuitable for exterior use.

Technical characteristics of the supports

- z225 hot-galvanized **pre-powder coated or lined steel sheet**, mini shade s280 GD+Z, according to standard NF EN 10326, thickness 0,50 mm *0.019"*, 0,63 mm *0.024"* or 0,75 mm *0.029"*

- **Stainless steel sheet** shades, thickness 0,60 mm *0.023"* or 0,80 mm *0.031"*

* x5CrNi 18-10 (EN 1-4301 or AISI 304)

* x2CrNiMo17-12-2 (EN 1-4404 or AISI 316L)

- **Pre-powder coated aluminium** shade EN AW.3004 H46 according to standard EN 1396, thickness 0,67 mm *0.026"*

Test types and results of various panel facings on galvanized steel sheets

	Testing standards and conditions	Polyester powder coat 25 µm	Conductive powder coat	PVDF powder coat 35 µm	PVC film 120 µm	PET 55 µm system
Category	XP P 34-301	IIIa		IVb	Vc	Vc
Gloss	ISO 2813 (ECCA-T2) incidence 60°	30 ± 6%	30 ± 6%	30 ± 6%	25%	30 ± 6%
Shock resistance	ISO 6272 (ECCA-T5)	No loss of panel face adherence				
Adherence by bending	ISO 1519 (ECCA-T7)	3t	3t	2t	0t	1t
Resistance to humidity	ISO 6270 (ECCA-T9)	≥ 1000 h	≥ 1000 h	≥ 1000 h	≥ 1000 h	≥ 1500 h
Resistance to neutral salt spray	ISO 7253 (ECCA-T8)	≥ 360 h	≥ 360 h	≥ 500 h	≥ 500 h	≥ 500 h
Chalk hardness	ISO 3270 (ECCA-T4)	H	H	HB	2H	2H
Adherence to panel face (grid pattern)	ISO 2409		Class «0»			
Panel face resistance to heat	ISO 3270 (ECCA-T13)	100 h to 80°C 176°F ΔE ≤ 0,1		100 h to 70°C 158°F ΔE ≤ 0,1	100 h to 70°C 158°F ΔE ≤ 0,1	
Resistance to abrasion	ISO 7784	40 mg	5.6 mg	30 mg	10 mg	
Reaction to fire	NF P 92-507	M0	M0	M0	M1	M0
Surface resistivity	ASTM D257	10 ¹¹ Ω/□	10 ⁷ Ω/□			

Special warning for HPL panel face

Compact laminated sheets are very sensitive to hygrometry conditions : high variation of dimensions under extreme high or low ambient humidity can occur.

For that reason, several precautions must be taken at the different production or delivery stages : HPL sheets or finished HPL panels must be stored under tight controlled ambient conditions: from 10 to 30°C 50°F to 86°F and relative humidity 40 to 60 %). Finished HPL panels should not be used under high temperature and/or high relative humidity conditions.

Storage and working conditions : The 2 sides of the HPL panels must remain aerated and within the average temperature range of 10 to 30°C 50°F to 86°F and relative humidity from 40 to 60 %.

Ignoring these warnings, bending or twisting of the HPL panels may occur.

Resistance of panel faces to chemical products

Information given as a guide only

Coatings		Polyester lacquer	Conductive lacquer	PVDF 35 µm 1.38 mils	PVC 120 µm 4.7 mils	PET 55 µm 2.16 mils	Compact laminated	Stainless steel 304 + PVC + PET	Stainless steel 304	Stainless steel 316L
Chemical products	Chemical family									
Acetone	Ketone	⊖	⊖	⊖	⊖	⊖	☺	☺	☺	☺
Acetic acid (CH ₃ COOH) (vinegar) 10%	Acid	⊖	⊖	☺	☺	☺	☺	☺	☺	☺
Hydrochloric Acid (HCl) 10%	Acid	⊖	⊖	⊖	⊖	☺	☺	✓	⊖	☺
Nitric acid (H ₂ NO ₃) 10%	Acid	⊖	⊖	☺	☺	☺	☺	☺	☺	☺
Phosphoric acid (H ₃ PO ₄) 10%	Acid	⊖	⊖	☺	☺	☺	☺	☺	☺	☺
Sulphuric acid (H ₂ SO ₄) 10%	Acid	⊖	⊖	☺	☺	☺	☺	☺	☺	☺
Ethyl alcohol - Methylated spirit	Alcohol	☺	☺	☺	☺	☺	☺	☺	☺	☺
Isopropyl alcohol	Alcohol	☺	☺	☺	☺	☺	☺	☺	☺	☺
Ammonia - NH ₄ OH	Base	⊖	⊖	☺	☺	☺	☺	☺	☺	☺
Ammonium bisulphite	Salt	☺	☺	☺	☺	☺	☺	☺	☺	☺
Buthanol	Alcohol	☺	☺	☺	☺	☺	☺	☺	☺	☺
Sodium hypochlorite - NaClO (Javel water) high concentration		⊖	⊖	⊖	⊖	☺	☺	✓	☺	☺
Therebentine	Alcohol	☺	☺	☺	☺	☺	☺	☺	☺	☺
MEK (Methyl ethyl Ketone)	Ketone	⊖	⊖	⊖	⊖	⊖	☺	⊖	☺	☺
Methanol	Alcohol	☺	☺	☺	☺	☺	☺	☺	☺	☺

Caption ⊖ Prohibited ☺ Recommended ✓ Suitable To be studied case by case

Resistance of panel faces to chemical products

Information given as a guide only

Coatings		Polyester lacquer	Conductive lacquer	PVDF 35 µm 1.38 mils	PVC 120 µm 4.7 mils	PET 55 µm 2.16 mils	Compact laminated	Stainless steel 304 + PVC + PET	Stainless steel 304	Stainless steel 316L
Chemical products	Chemical family									
Phenol	Alcohol	☺	☺	☺	☺	☺	☺	☺	☺	☺
Potash - Potassium hydroxide - KOH - 10%	Base	☹	☹	☺	☺	☺	☺	☺	☺	☺
Alkaline industrial soap	Base soap	☹	☹	☺	☺	☺	☺	☺	☺	☺
Chlorinated industrial soap	Neutral soap	☹	☹	☺	☺	☺	☺	☺	☺	☺
No chlorinated industrial soapé	Neutral soap	☺	☺	☺	☺	☺	☺	☺	☺	☺
Kitchen salt (Sodium chloride - NaCl)	Salt	☹	☹	☹	☹	☹	☺	☺	☺	☺
Kitchen salt + use of acidic cleaning agents	Salt + Acid	☹	☹	☹	☹	☹	☹	☑	☹	☺
Sodium hydroxide - NaOH - 10%	Base	☹	☹	☹	☺	☺	☺	☺	☺	☺

Panel face resistance to hydrogen peroxide H2O2 (oxygenated water) (fogging tests)

Materials	Pre-coated sheet - polyester 25 µm 0.98 mil - PVDF 35 µm 1.38 mil - lacquer thk. ≤ 50 µm 1.97 mil	Painted sheets - paint 50 µm 1.97 mil ≤ thk. < 80 µm 3.15 mil	Painted sheets - paint thk. ≥ 80 µm 3.15 mil	Film clad sheets (process) - PET 55 µm 2.16 mil - PVC 120 µm 4.7 mils	Compact laminated	Stainless steel 304 + PVC + PET	Untreated stainless steel 304, 316L,
Decontamination frequency							
Low	☹	☹	☑	☺	☺	☺	☺
Average	☹	☹	☑	☺	☑	☺	☺
High	☹	☹	☹	☑	☑	☑	☺

Refer to Chapter 12 – Panel face shade chart for further information.



Midnight blue
RAL 5011



Pacific blue
RAL 5010



Horizon blue
RAL 5015



Glacier blue
Pantone 278C



Lagoon green
RAL 6027



Meadow green
RAL 6018



Forest green
RAL 6029



Sulphur yellow
RAL 1016



Pale orange
Pantone 1495



Bright pink
RAL 3015



Molten red
RAL 3020



Canyon red
RAL 3013



Storm grey
RAL 7040



Pebble white
RAL 9002



Iceberg white
RAL 9010

Ours colours are close to RAL and Pantone references.